

| HOLE | DIA. | QTY. | APPLICATION |
|------|----------------|------|----------------|
| A | 0.438 11.11 | 4 | FLOOR MOUNTING |

NEMA-4/12/13 ENCLOSURES FEATURE NO PRE-FABRICATION PROVISIONS FOR CONDUIT ENTRANCE. CABINET SHOULD BE FIELD-MODIFIED BY INSTALLER AS NEEDED FOR I/O.

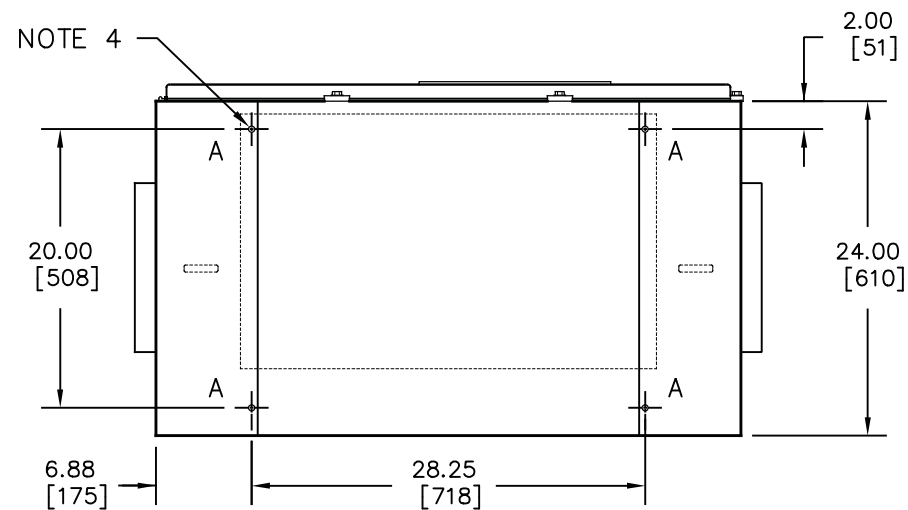
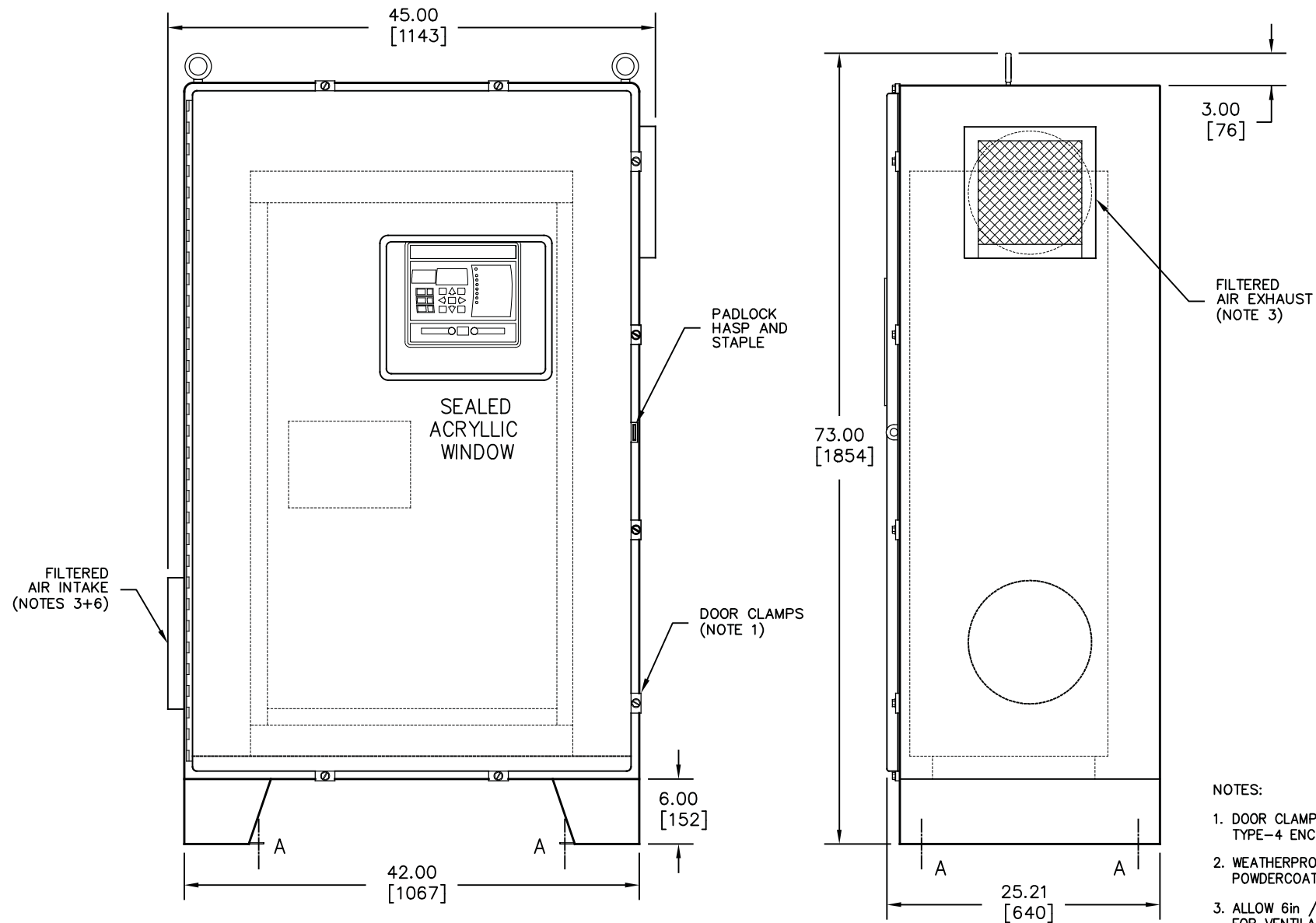

NOTES:

1. DOOR CLAMPS AND GASKETS SUPPLIED TO MEET NEMA TYPE-4 ENCLOSURE STANDARDS.
2. WEATHERPROOF ENCLOSURE FINISH IS ANSI-61 GRAY EPOXY POWDERCOAT.
3. ALLOW 6in / 152mm OF FREE AIR ON SIDES OF CABINET FOR VENTILATION.
4. UNIT IS FLOOR MOUNTED AND WIRED PER TABLE ABOVE.
5. ENCLOSURE (NOT INCLUDING INTERNAL CHARGER) APPROXIMATE SHIPPING WEIGHT: 360 lb / 16 kg
6. SHEE SHEET 2 OF 2 FOR INTERNAL CONFIGURATION AND POWERED FAN.
7. LIFTING EYE BOLTS SUPPLIED ON CABINET AS SHOWN.

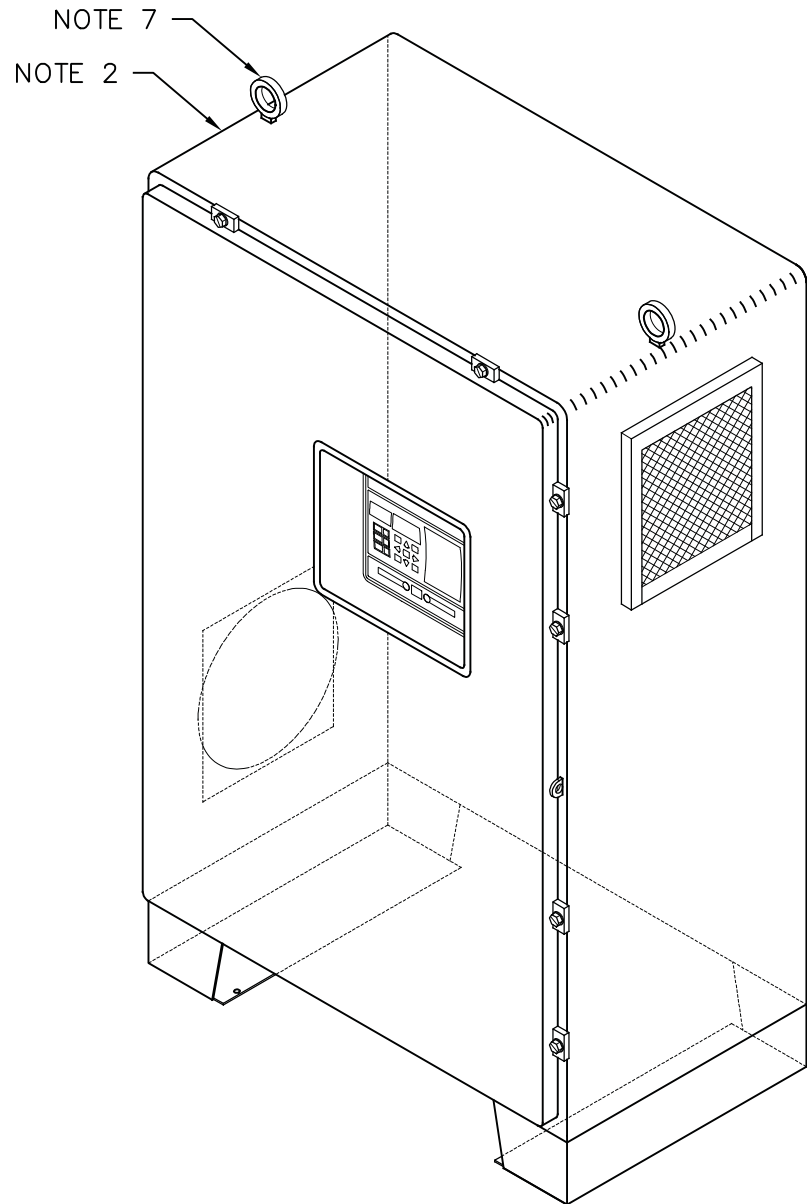

DUAL DIMENSIONS in [mm]

| | | | | | | |
|-----------------------------------|---------------|---------------|-------------------|---------------|-------------------|---|
| REV. DRN BY 0 KJB | CHK BY MCR | APP BY MCR | DATE 3/24/2022 | DRN BY KJB | DATE 3/22/2022 | TITLE ATevo SERIES BATTERY CHARGER OUTLINE: NEMA-4 ENCL. STYLE-5057 CABINET |
| DESCRIPTION APPROVAL DRAWINGS. | | | | CHK BY MCR | DATE 3/22/2022 | |
| ECN NO. N/A | | | | CHK BY MCR | DATE 3/22/2022 | |
| | | | | | | B SCALE NTS |
| DWG No JE5108-50 | | | | | | REV 0 |
| SHEET 1 OF 2 | | | | | | |

SECTION B-B

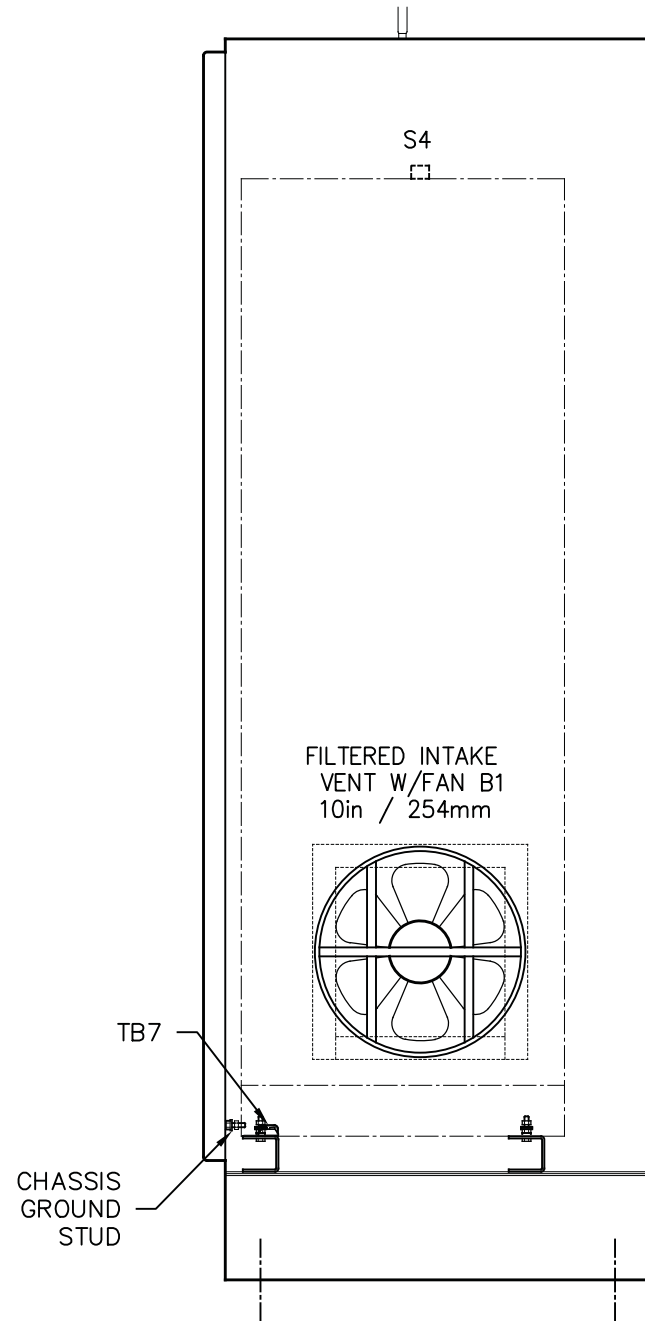

B

STYLE-5030 ENCLURE (NOTE 1)

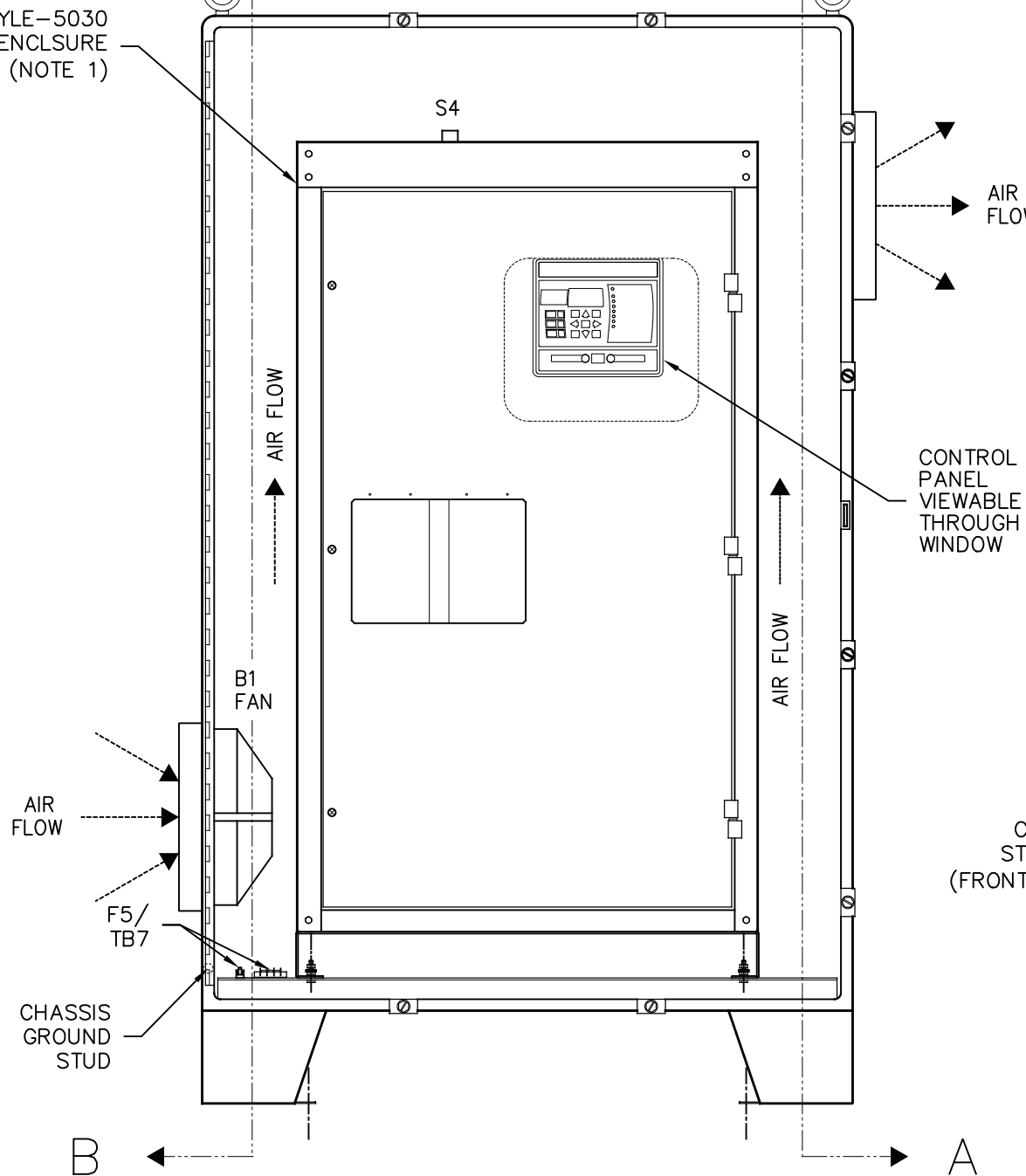

A

SECTION A-A

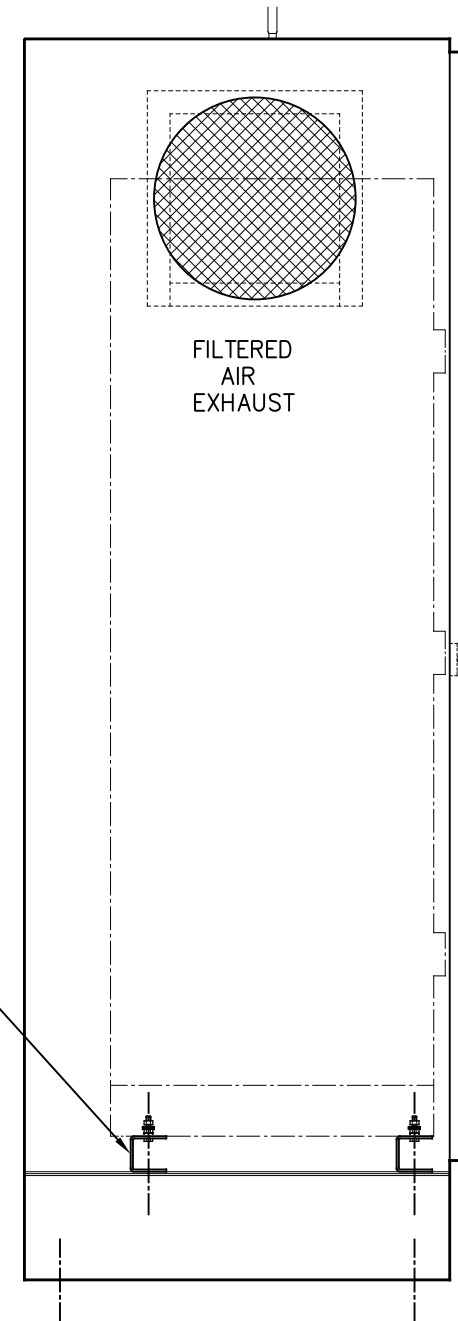

B

A

WIRE LIST:

| No. | FROM | TO | GA | COLOR |
|-----|---------|----------------|----|---------|
| 196 | TB7-L1 | F5-1 | 14 | BLACK |
| 197 | F5-2 | S4-1 | 14 | BLACK |
| 198 | S4-2 | B1-1 | 14 | BLACK |
| 199 | B1-2 | TB7-N | 14 | BLACK |
| 200 | TB7-GND | CHASSIS GROUND | 12 | GRN/YEL |

NOTES:

- THIS DRAWING DEPICTS A NEMA TYPE-4 / IP66 CABINET, HOUSING A STANDARD NEMA-1 ATevo SERIES BATTERY CHARGER. SEE JE5337-1039410 FOR INTERNAL STYLE-5030 ENCLOSURE DIMENSIONS.
- TB7 3-POS FAN EXTERNAL POWER TERMINAL BLOCK BARRIER TYPE, 6-32 BINDER HEAD SCREW TERMINAL, WILL ACCOMMODATE LUGS FOR #22-14 AWG WIRE.
- VENTING FAN (B1) IS INTERMITTENT, ACTIVATED BY THERMAL SWITCH (S4), WHICH CLOSES ON RISE TO 105 °F / 40.6 °C, AND IS SELF-RESETTING.
- NEMA-4 CABINET INTERNAL FINISH IS ANSI-61 GRAY.

USER-SUPPLIED FAN POWER INPUT 120VAC-1PH-60Hz (SEE NOTE 2)

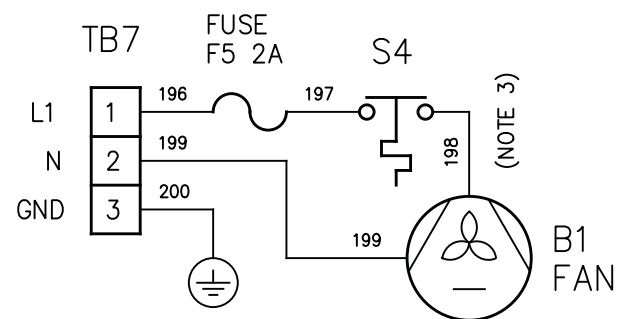

| | |
|---------------|--------------------|
| DRN BY KJB | DATE: 3/22/2022 |
| CHK BY MCR | DATE: 3/22/2022 |
| CHK BY MCR | DATE: 3/22/2022 |

TITLE
**ATEVO SERIES BATTERY CHARGER
OUTLINE: NEMA-4 ENCL. STYLE-5057 CABINET**



B

SCALE
NTS

DWG No

JE5108-50

REV
0

SHEET
2 OF 2