

GROUND PAD
(ALSO ON REAR)

- DESIGN NOTES:
- ENCLOSURE IS A NEMA-1 TYPE CABINET WITH GASKETING AND FOAM INJECTED PANELING. FINISH IS ANSI 61 GREY POWDERCOAT.
 - LOCATE UNIT ONTO A PERMANENT, FLAT, AND LEVELED SURFACE, PREFERABLY CONCRETE OR OTHER FIREPROOF MATERIAL. SURFACE MUST BE CAPABLE OF SUPPORTING WEIGHT OF COMPLETE SYSTEM AND INSTALLED COMPONENTS. SEE FOUNDATION DRAWING (JE5276-01) FOR LOADING INFORMATION.
 - THE WEIGHT OF THE CONSOLE WITHOUT BATTERIES IS 497lb [225kg]
 - FOR LIFTING, USE OPTIONAL STRAPPING SYSTEM SEE E15196-01.

REV	DRN BY	CHK BY	APP BY	DATE	DRN BY	DATE	DRN BY	DATE	HINDLEPOWER <small>1075 Smt. 1st Fl. Dept. Statesville, NC 28687 Tel: 704-885-1000 Fax: 704-885-1001 www.hindlepower.com</small>	
0	KJB	RCF	RCF	04/09/24	KJB	04/09/24	KJB	04/09/24		
DESCRIPTION Initial Release					CHK BY RCF	DATE 04/09/24	APP BY RCF	DATE 04/09/24	TITLE EPIC SERIES 2.0 CONSOLE OUTLINE: NEMA 3R STYLE 5063 ENCL SALES ORDER No. n/a	
					<small>UNLESS OTHERWISE SPECIFIED ALL DIMENSIONS FOLLOW THE ANSI Y14.5M-1994 (INCHES, POUNDS & SECONDS) TOLERANCES ARE: DIM. < 1.00 DEC. ± 0.125; ANG. ± 25'</small>		SCALE 1:10	DWG No. JE5269-01	REV 0	SHEET 1 OF 1

8

7

6

5

4

3

2

1

D

D

C

C

B

B

A

A

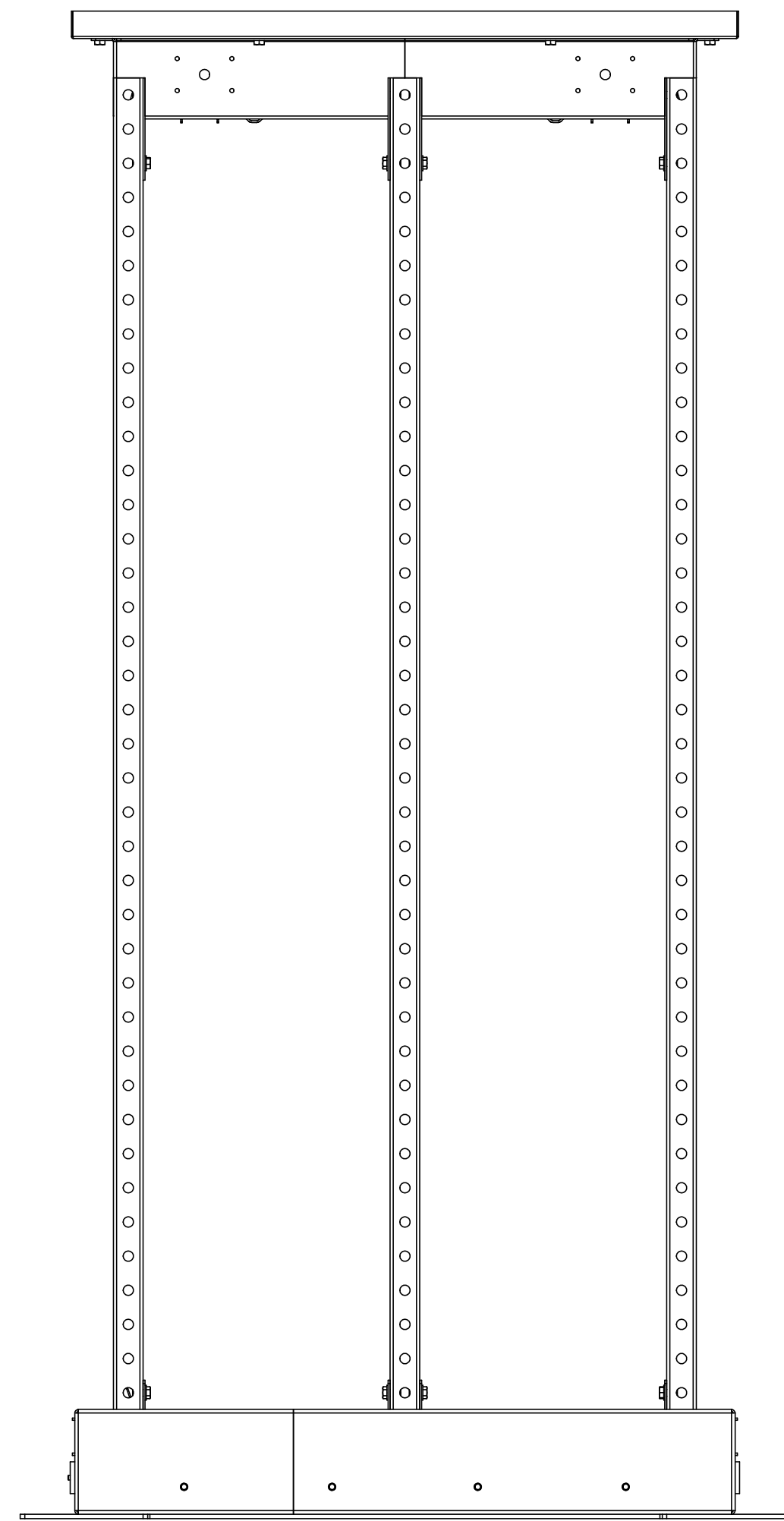
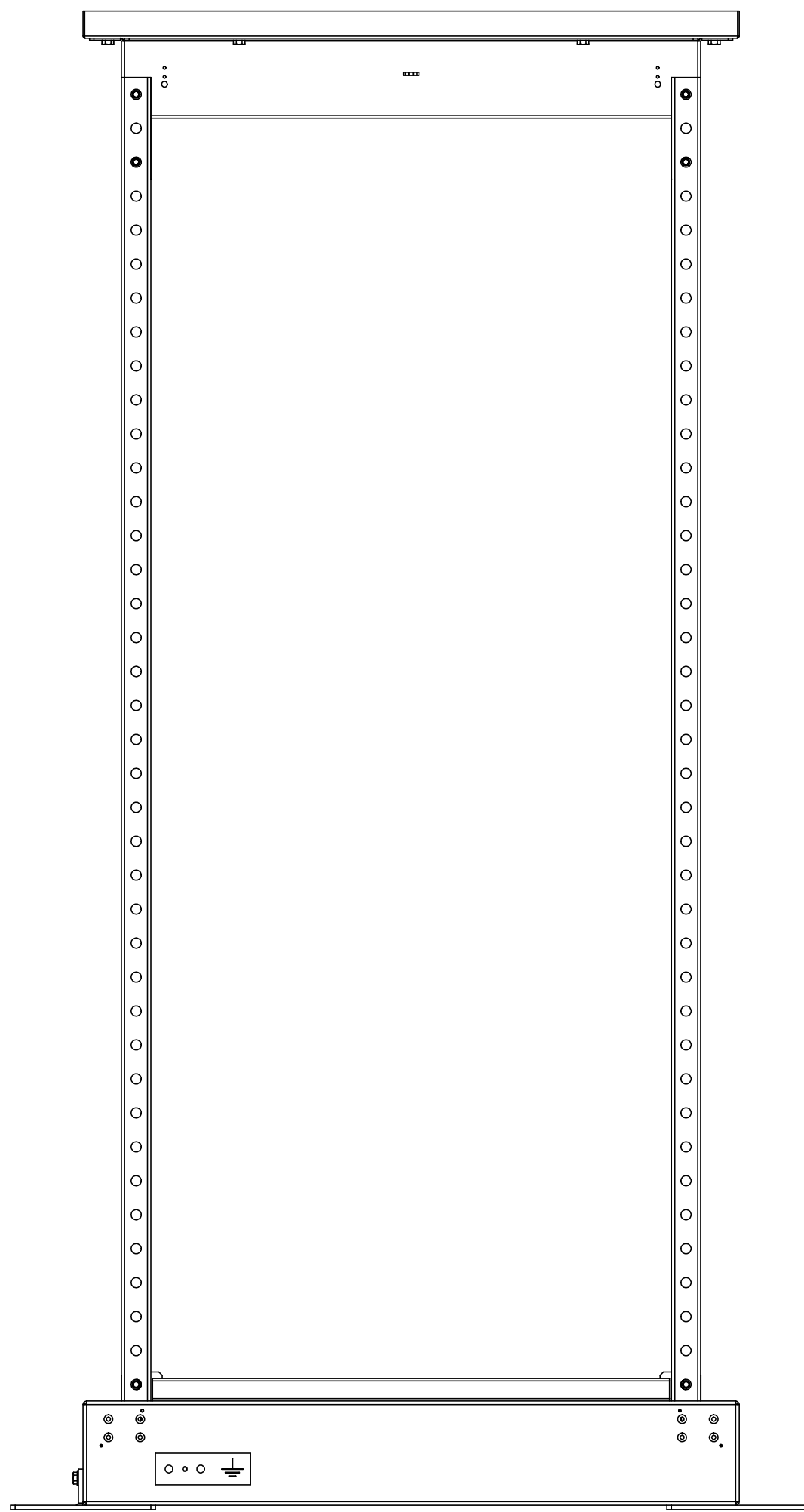
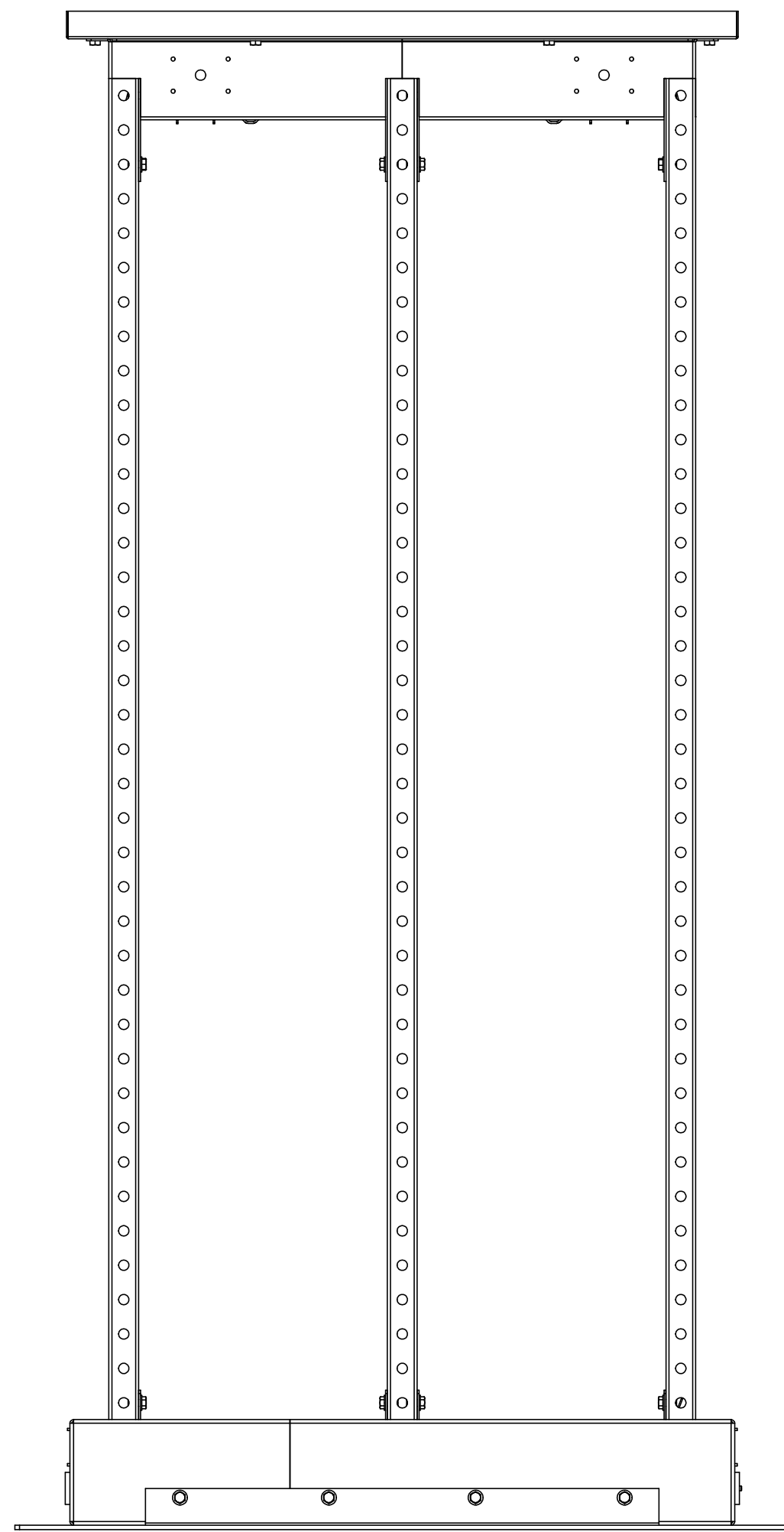

1. TO PROVIDE A CLEAR VIEW OF THE CONSOLE INTERNAL COMPONENTS, THE FOLLOWING ITEMS ARE NOT SHOWN:
 - FRONT DOORS
 - REAR PANELS/DOORS
 - LEFT AND RIGHT SIDE PANELS
2. DO NOT LIFT, PUSH OR RELOCATE THE EPIC CONSOLE WITH BATTERIES INSTALLED WITHIN ENCLOSURE.
3. BATTERY TYPE: ## (## JARS)

REV	DRN BY	CHK BY	APP BY	DATE	DRN BY	DATE	HINDLEPOWER <small>1075 South 10th Street Suite 100, Mesa, AZ 85204 Tel: 480.962.1000 www.hindlepower.com</small>
0	KJB	RCF	RCF	04/09/24	KJB	04/09/24	
DESCRIPTION				CHK BY	DATE	TITLE	
Initial Release				RCF	04/09/24	EPIC SERIES 2.0 CONSOLE	
APP BY				DATE	INTERNAL LAYOUT: 0 ELEC. / 1 BATT.		
RCF				04/09/24	SALES ORDER No. n/a		
UNLESS OTHERWISE SPECIFIED				SCALE			
ALL DIMENSIONS FOLLOW THE				1:8			
ANSI 91.1 (INCHES)				DWG No.			
ANSI 91.1 (MILLIMETERS)				JE5270-01			
TOLERANCES ARE: FRACTIONS: 1/16"				REV			
DECIMALS: 0.015, 0.031, 0.062"				SHEET			
				0 1 OF 1			

8

7

6

5

4

3

2

1

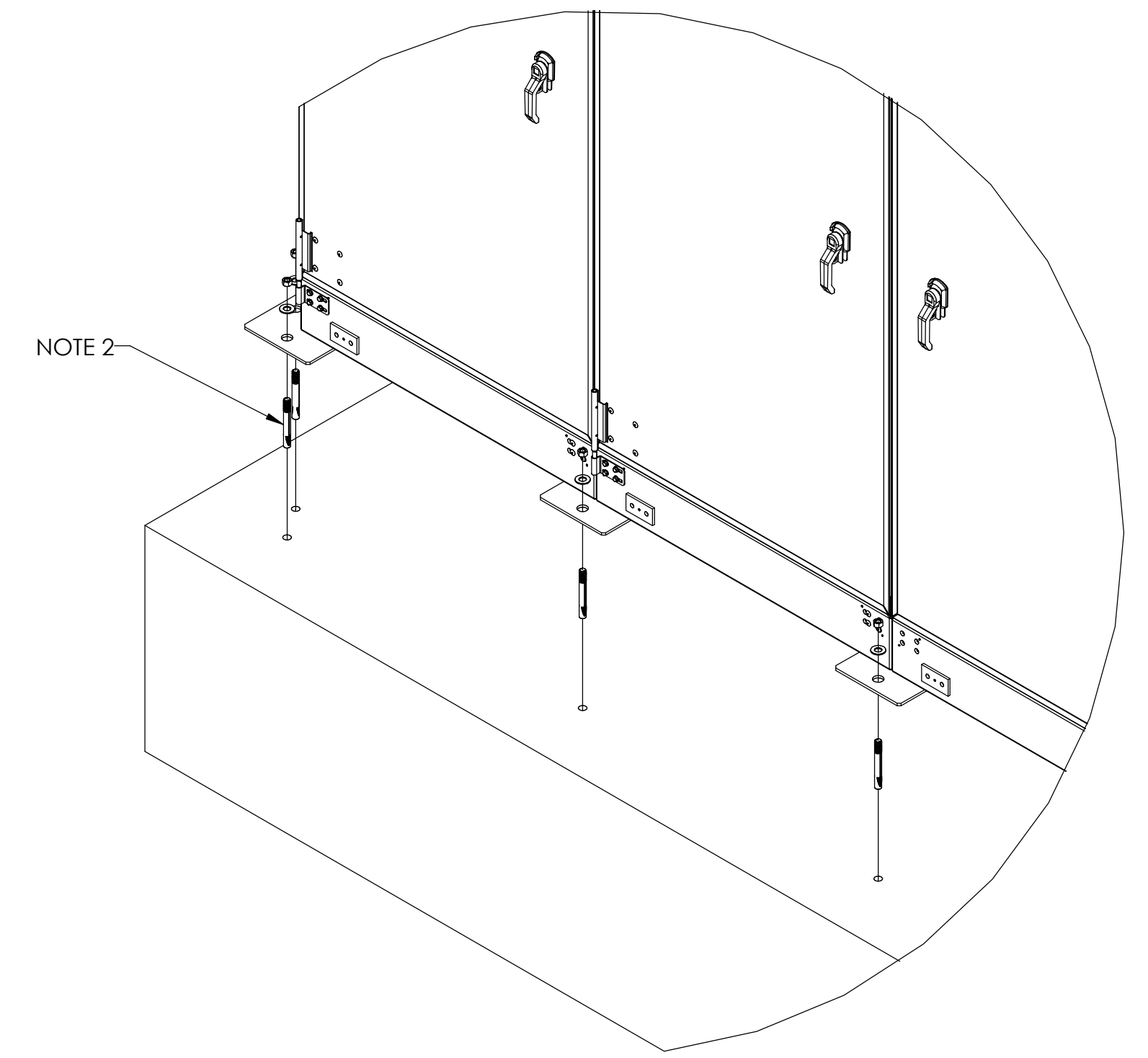
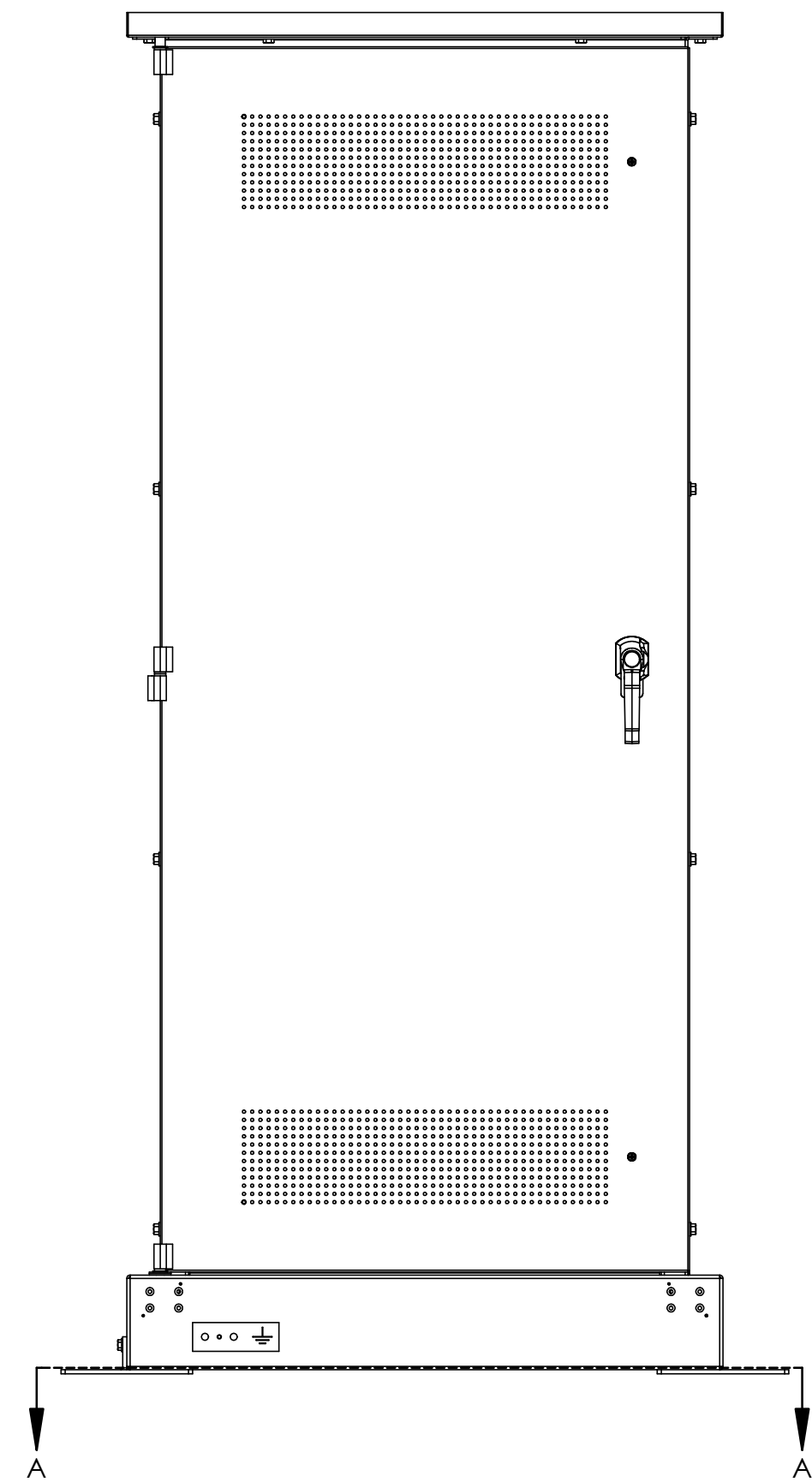
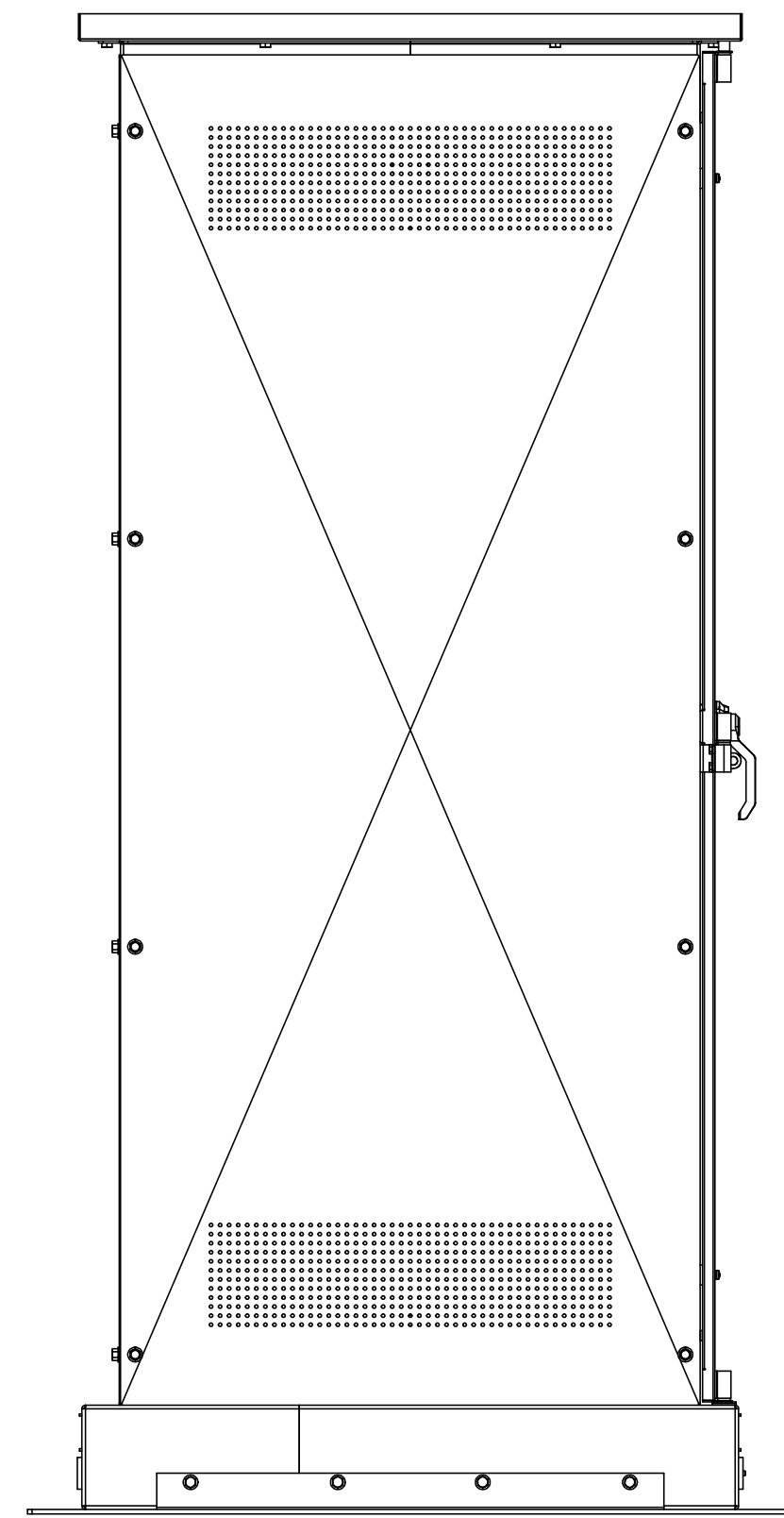

STUB-UP LOCATIONS
DETAIL B
SCALE 1 : 8

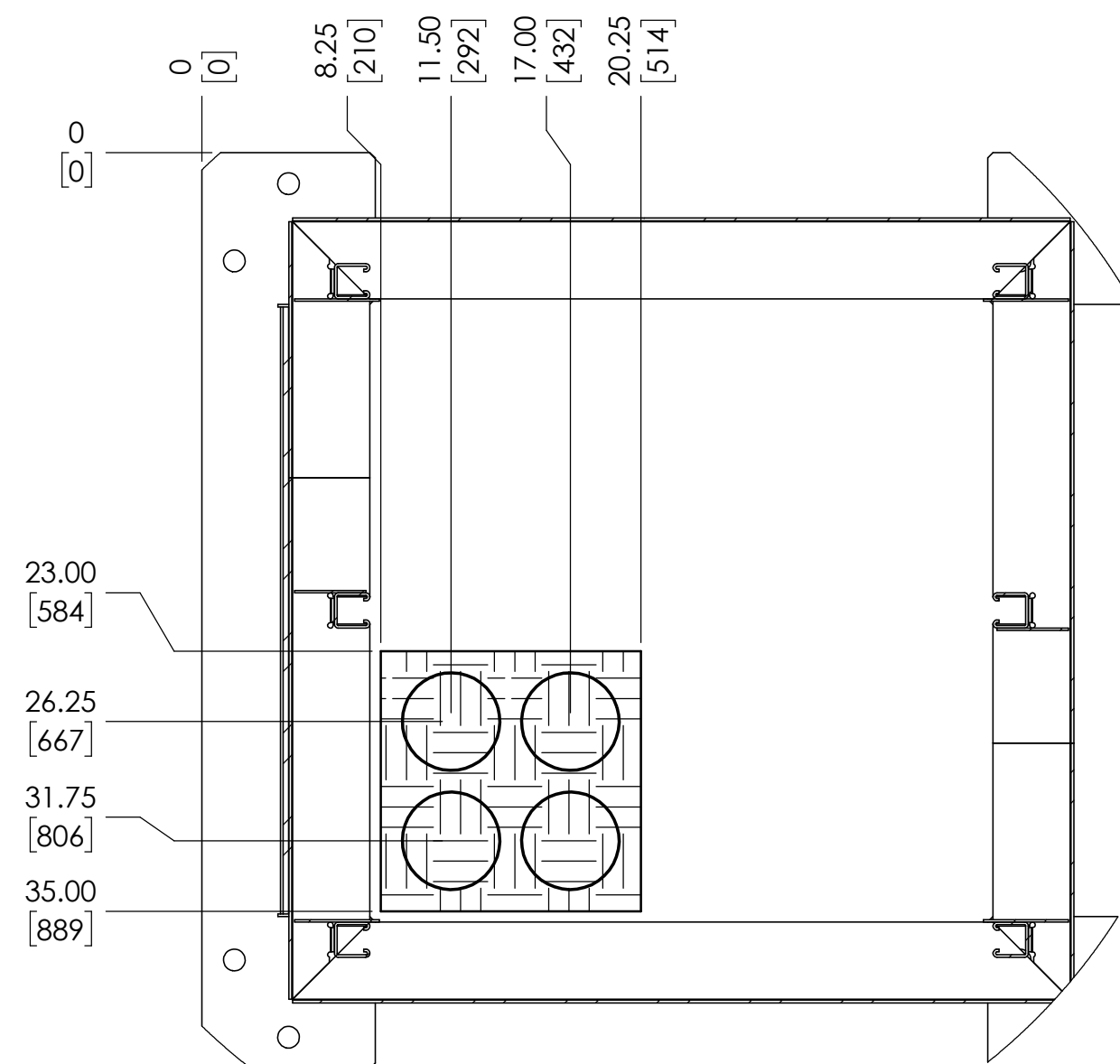

A-A
MOUNTING DIMENSIONS

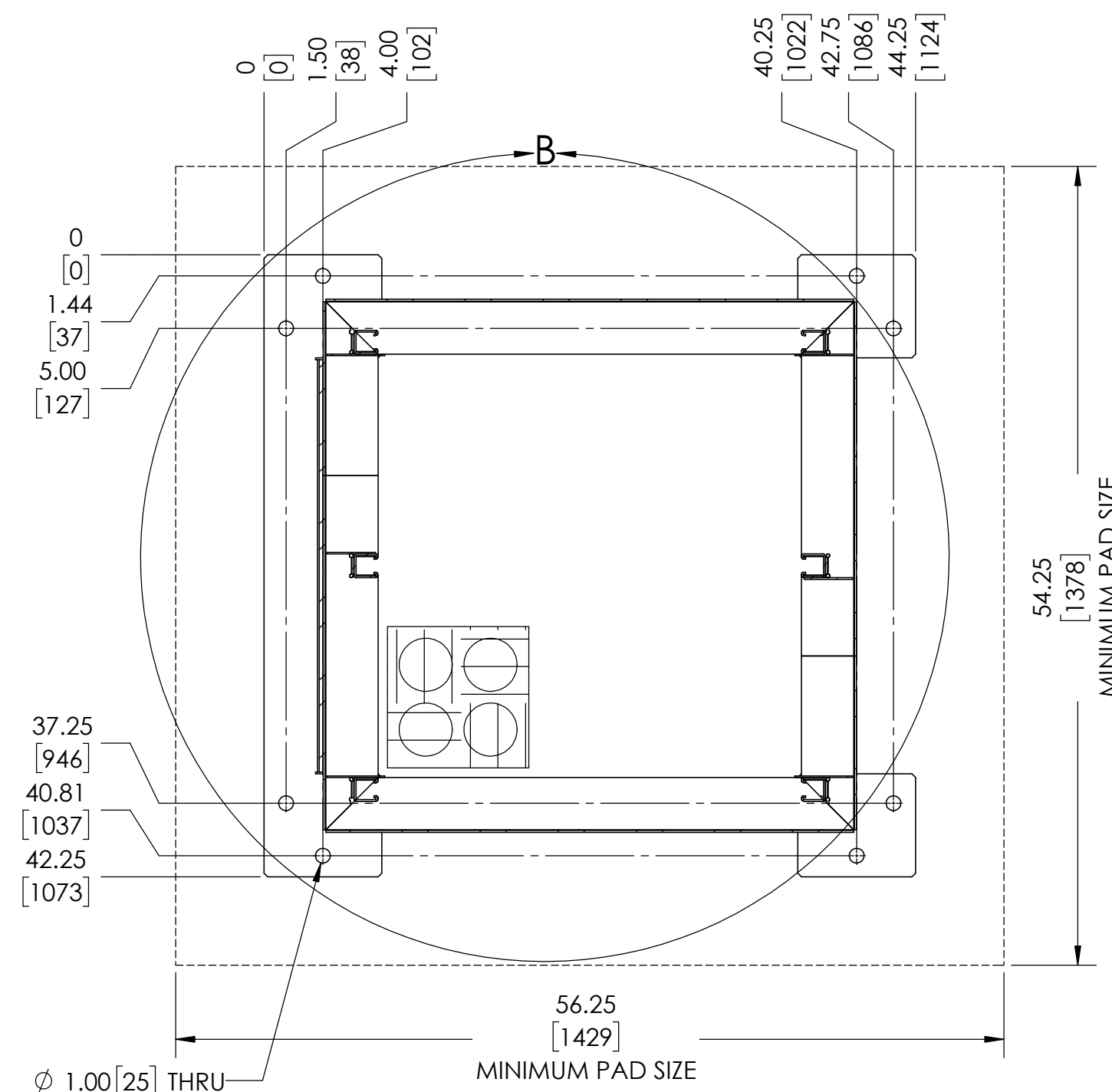

NOTES:

1. MOUNTING DIMENSIONS SHOWN ON DRAWING ARE FINAL. WE RECOMMEND PLACING CONSOLE THEN DRILLING FOR MOUNTING ANCHORS.
2. ANCHOR BOLTS ARE TO BE HILTI M12 HDA-TR STAINLESS STEEL UNDERCUT (OR EQUIVALENT). HOLE DEPTH TO BE MINIMUM OF 5.3" [135mm], PAD DEPTH TO BE MINIMUM OF 8.0" [203mm]
3. CONCRETE PAD TO EXTEND A MINIMUM OF 6" [153mm] FROM EDGE OF CABINET ON ALL SIDES. SEE MOUNTING DIMENSIONS TO LEFT. THE WEIGHT OF THE CONSOLE WITH BATTERIES (SPECIFIED IN PURCHASE ORDER) IS 497lb [225kg]
4. CONCRETE PAD TO BE 4000 psi OR GREATER.
5. ELECTRICAL CONDUIT MAY ENTER FROM UNDERNEATH CABINET, BUT ONLY THROUGH STUB-UP LOCATIONS SHOWN IN DETAIL B.
6. CONDUIT ENTRY POSSIBLE THROUGH FIELD MODIFIED SIDE.

REV DRN BY CHK BY APP BY DATE	DRN BY DATE	DRN BY DATE		HINDLEPOWER <small>1075 East 10th Street Suite 100, Bend, OR 97701 www.hindlepower.com</small>
0 KJB RCF RCF 04/09/24	KJB 04/09/24	KJB 04/09/24		
DESCRIPTION	CHK BY DATE	CHK BY DATE	TITLE	
Initial Release	RCF 04/09/24	RCF 04/09/24	EPIC SERIES 2.0 CONSOLE FOUNDATION DRAWINGS SALES ORDER No. n/a	
APP BY DATE	APP BY DATE	APP BY DATE	SCALE	DRWG No.
RCF 04/09/24	RCF 04/09/24	RCF 04/09/24	D 1:10	JE5276-01
<small>UNLESS OTHERWISE SPECIFIED: ALL DIMENSIONS EXCEPT THE INCHES IN PARENTS & SECONDS TO FRANCES ARE: FPM3C 1/16" DEC ± 0.10, ANG ± 0.5°</small>			REV	SHEET
			0	1 OF 1