

BACK OF FRONT DOOR

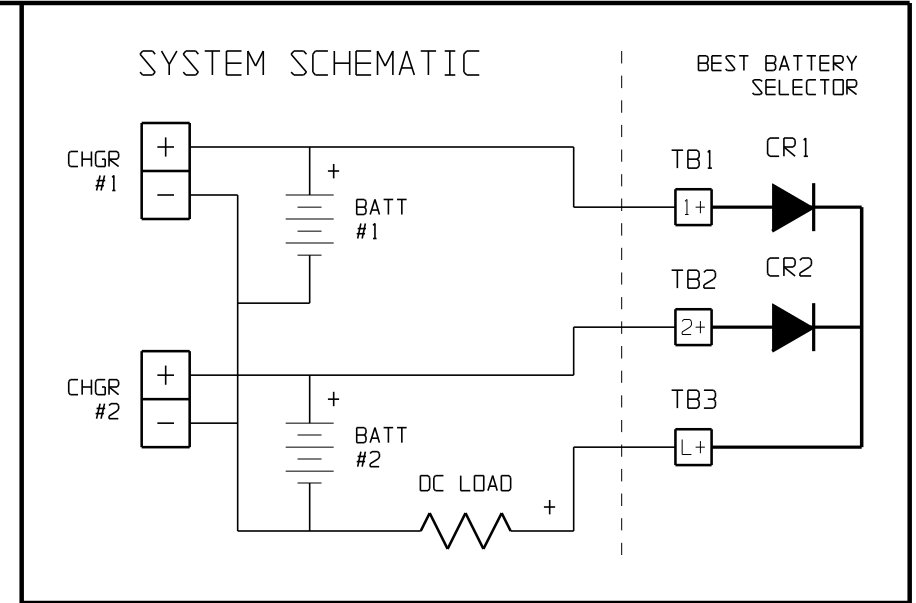

NOTES:

- \* STEERING DIODES LINK TWO (2) BATTERY CHARGER DC OUTPUT BUSES TO COMMON LOAD WITHOUT LINKING BATTERY BANKS TOGETHER, SEE OPERATING INSTRUCTIONS (JA5065-00)
- \* STEERING DIODES AND I/O TERMINALS (TB#) FEATURE HARD-BOLT CONNECTIONS, NO FLEXIBLE WIRING IS USED
- \* USER CONNECTIONS:  
500 ADC - THREE (3) CU-AL COMPRESSION LUGS  
WILL ACCEPT #2 AWG - 600 MCM WIRING

PART No.	VOLTAGE RATING	CURRENT RATING
EJ5144-03	250 VDC	500 ADC
EJ5144-07	600 VDC	500 ADC

		THIRD ANGLE PROJECTION		 1075 Saint John Street Easton, PA 18042-6661 PH 610-330-9000 FAX 610-330-8510 www.hindlepowerinc.com	
0	23733	052813	DRAWN BY MCR	080109	TITLE BEST BATTERY SELECTOR INTERNAL COMPONENT LAYOUT: NEMA-1 STYLE-1B ENCL (500Adc)
D	N/A	080109	ELECTRONIC APPROVAL SIGNATURES MAINTAINED BY MFG ECN LOG		DRAWING No JE5139-02
A-C	-N/A-	-N/A--	UNLESS OTHERWISE NOTED DIMENSIONS ARE IN INCHES. TOLERANCES ARE:		REV 0 <b>B</b>
REV	ECN No	DATE	SCALE NTS	PART No JE5139-02	SHEET 1 OF 1