

(1) 2 TON MINIMUM
CAPACITY SHACKLE
(NOT SUPPLIED)

3" x 24' DOUBLE EYE
FLAT LIFTING STRAP
4700LB VERTICAL\
9400LB BASKET
CAPACITY
(2 SUPPLIED)

2" x 3' DOUBLE EYE
FLAT LIFTING STRAP
3100LB VERTICAL
CAPACITY
(4 SUPPLIED)

PASS 3" STRAP THROUGH
EYES OF 2" STRAP
BOTH SIDES

! DO NOT LIFT IF
STRAPS ARE NOT
AT 60"

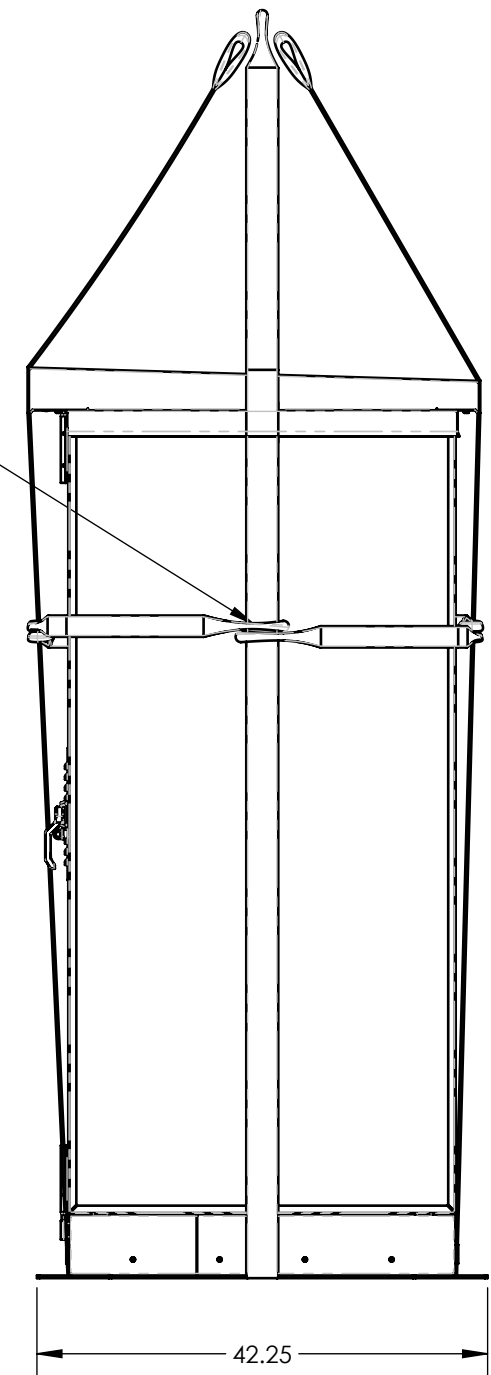
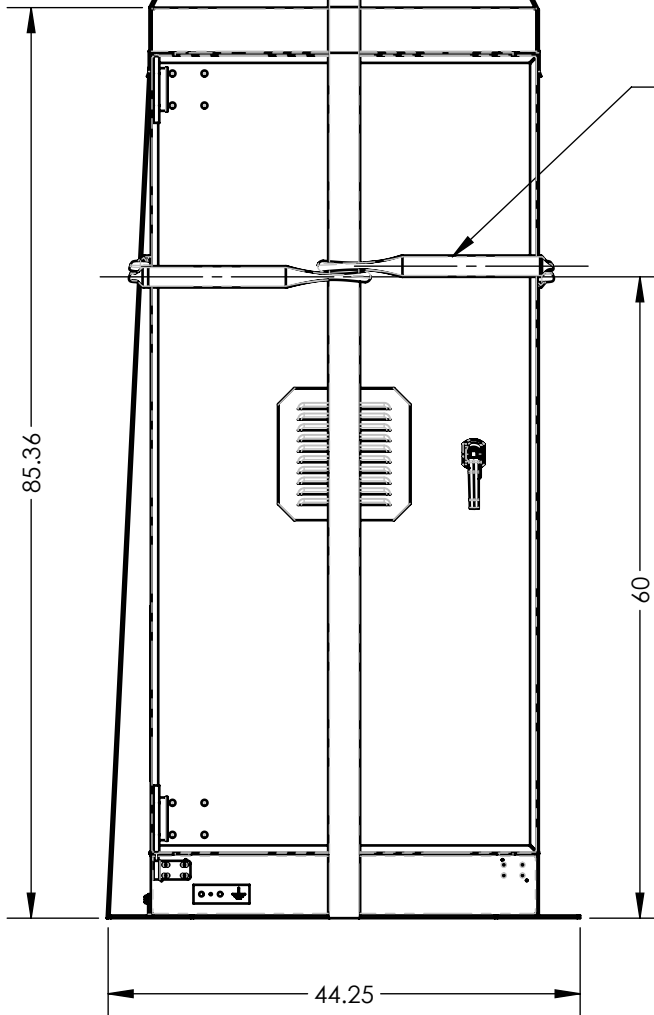

! ENSURE A SAFE WORK AREA CLEAR OF OBSTRUCTIONS IN THE SWING PATH OR LIFT VEHICLE PATH
ENSURE THE AREA IS CLEAR OF ANY OVERHEAD OBSTICLES SUCH AS ELECTRICAL WIRES
DO NOT LIFT WITH BATTERIES INSTALLED!

SEE SUPPLIED CUSTOMER DRAWINGS FOR JOB SPECIFIC INFORMATION
UNIT WEIGHT
CENTER OF GRAVITY
OVERALL DIMENSIONS

D:\Hindle Vault\Parts Directory\E - Assemblies\EI - Mechanical Assemblies\EI5196\EI5196-01

REV: 0	DRN BY: KCL	CHK BY: KCL	APP BY: KCL	DATE: 7/28/2020		HINDLEPOWER
DESCRIPTION: Initial Release				DATE: 7/30/2020		
UNLESS OTHERWISE SPECIFIED ALL DIMENSIONS FOLLOW THE ANSI SYSTEM IPS (INCHES-POUNDS & SECONDS) TOLERANCES ARE: FRAC. ±1/64, DEC. ±0.15, ANG ±.25°				DATE: 7/30/2020		
PROPRIETARY AND CONFIDENTIAL NOTICE ANY REPRODUCTION, PARTIAL OR AS A WHOLE OF THIS DOCUMENT WITHOUT THE WRITTEN PERMISSION OF HINDLE POWER, INC IS STRICTLY PROHIBITED.						TITLE: EPIC CONSOLE SLING LIFTING DRAWING SINGLE DOOR SETUP
SCALE: 1:18 DWG No: EI5196-01					REV: 0 SHEET: 1 OF 1	