

TAG	SIZE	QUANTITY	APPLICATION
A	Ø0.438in Ø11.11mm	4	FLOOR MOUNTING

NEMA-4 (12/13) ENCLOSURES FEATURE NO PRE-FABRICATION PROVISIONS FOR CONDUIT ENTRANCE. CABINET SHOULD BE FIELD-MODIFIED BY INSTALLER AS NEEDED FOR I/O.

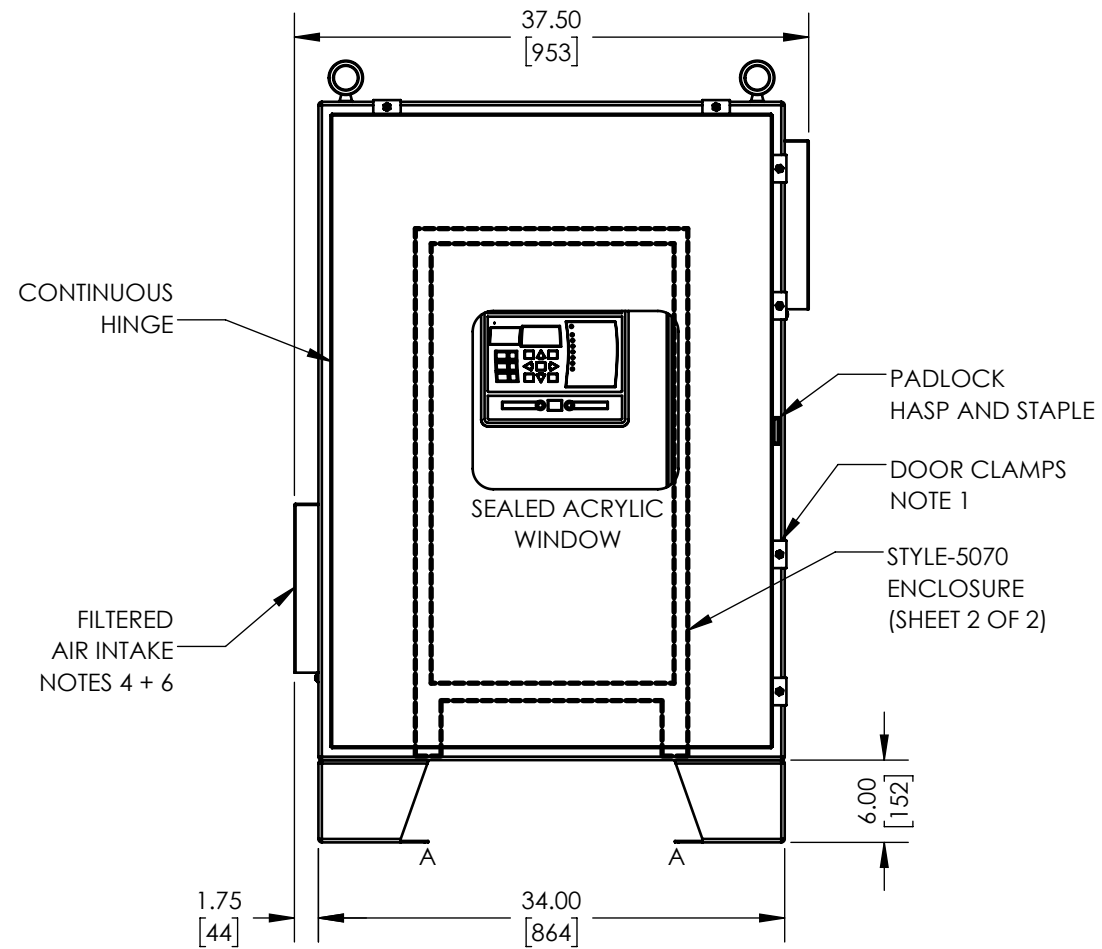

FRONT VIEW

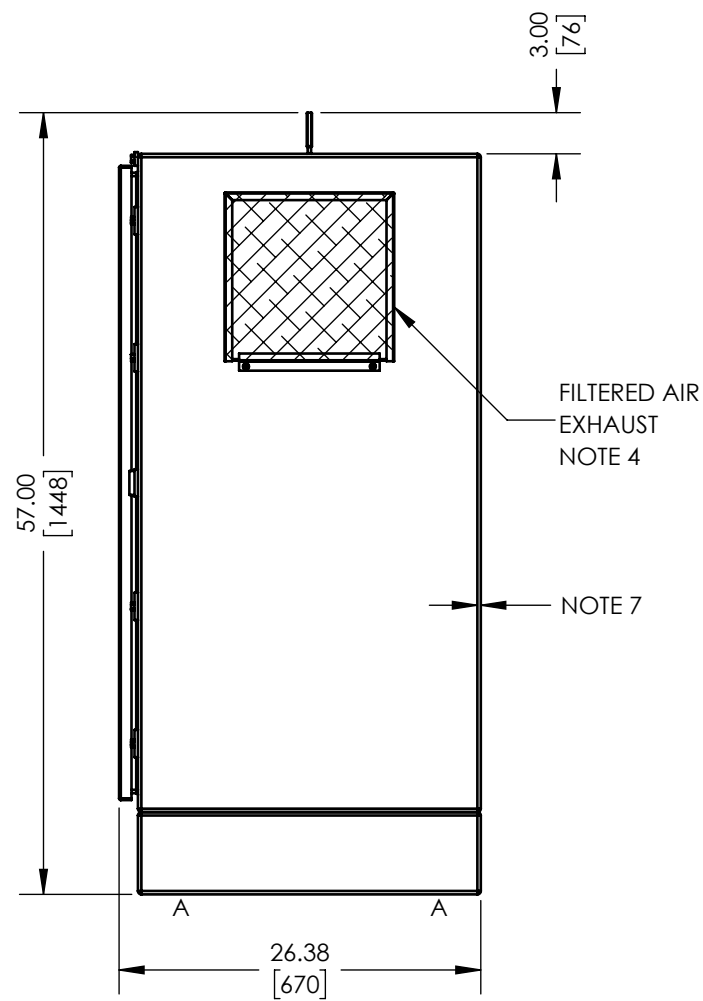

RIGHT VIEW

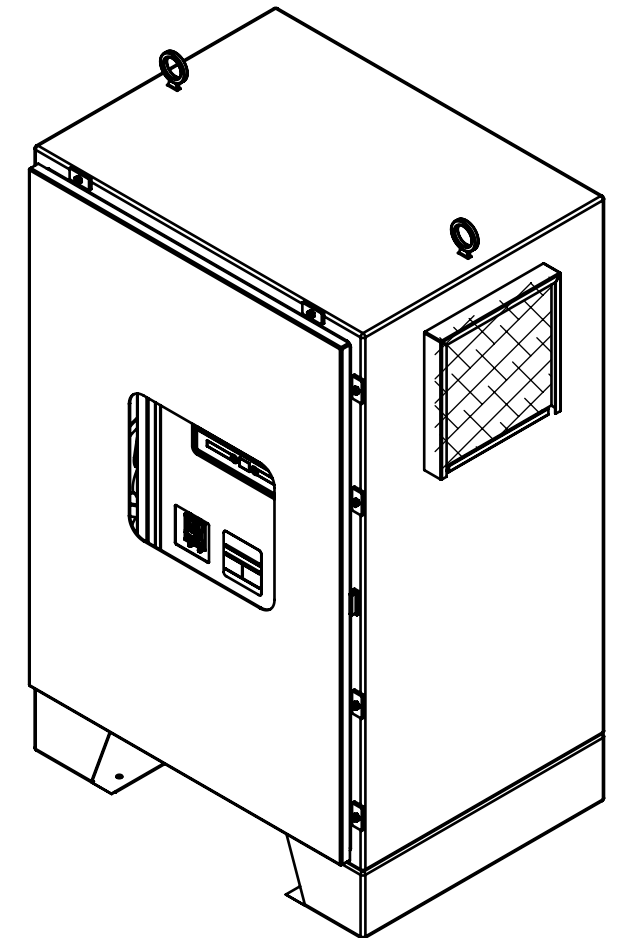

ISO VIEW

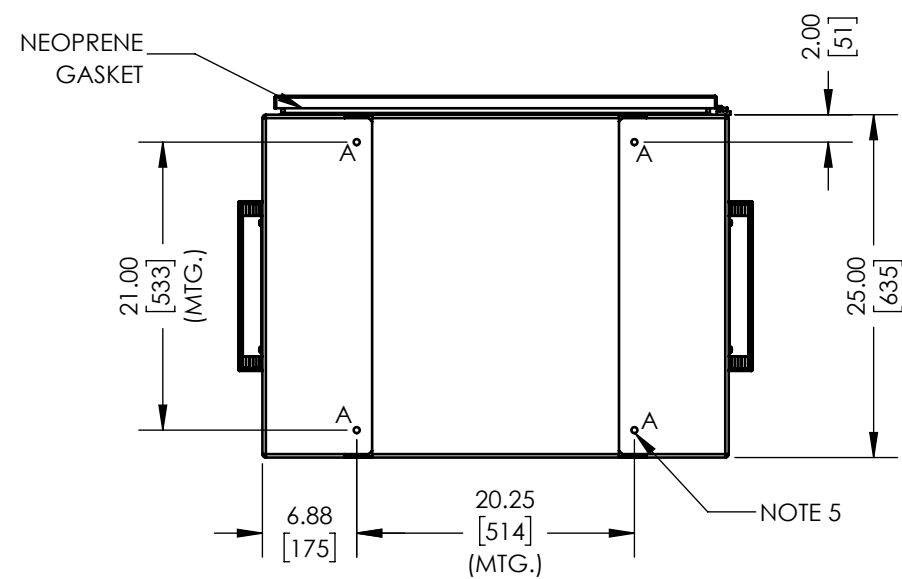

BOTTOM VIEW

NOTES:

- DOOR CLAMPS SUPPLIED TO MEET NEMA TYPE 4 / IP66 ENCLOSURE STANDARDS
- ENCLOSURE FINISH IS ANSI-61 GRAY EPOXY POWDERCOAT
- SHIPPING WEIGHT IS APPROXIMATELY:
380lb / 172kg ABOVE STANDARD CHARGER WEIGHT
- ALLOW 12in / 305mm OF FREE AIR ON SIDES OF CABINET FOR VENTILATION
- UNIT IS FLOOR MOUNTED AND WIRED PER TABLE ABOVE
- SEE SHEET 2 OF 2 FOR EXTERNALLY-POWERED INTAKE FAN AND 120Vac TERMINAL BLOCK
- ENCLOSURE SIDEWALLS ARE 12 GA CR STEEL

DUAL DIMENSIONS in [mm]

REV. 0	DRN BY	CHK BY	APP BY	DATE 1/6/2023	DRN BY <i>KB</i>	DATE: 1/4/2023	TITLE Atevo SERIES BATTERY CHARGER CABINET OUTLINE: NEMA TYPE 4 (12/13) STYLE-5037 ENCLOSURE	
DESCRIPTION Initial Release				CHK BY <i>MCR</i>	DATE: 1/6/2023	APP BY <i>MS</i>		DATE: 1/11/2023
UNLESS OTHERWISE SPECIFIED ALL DIMENSIONS FOLLOW THE ANSI SYSTEM IPS (INCHES-POUNDS & SECONDS) TOLERANCES ARE: FRAC. ±1/64, DEC. ±0.015, ANG ±.25°				PROPRIETARY AND CONFIDENTIAL NOTICE ANY REPRODUCTION, PARTIAL OR AS A WHOLE OF THIS DOCUMENT WITHOUT THE WRITTEN PERMISSION OF HINDLE POWER, INC IS STRICTLY PROHIBITED.		SCALE DWG No B 1:14 JE5074-50		
							REV 0	SHEET 1 OF 2

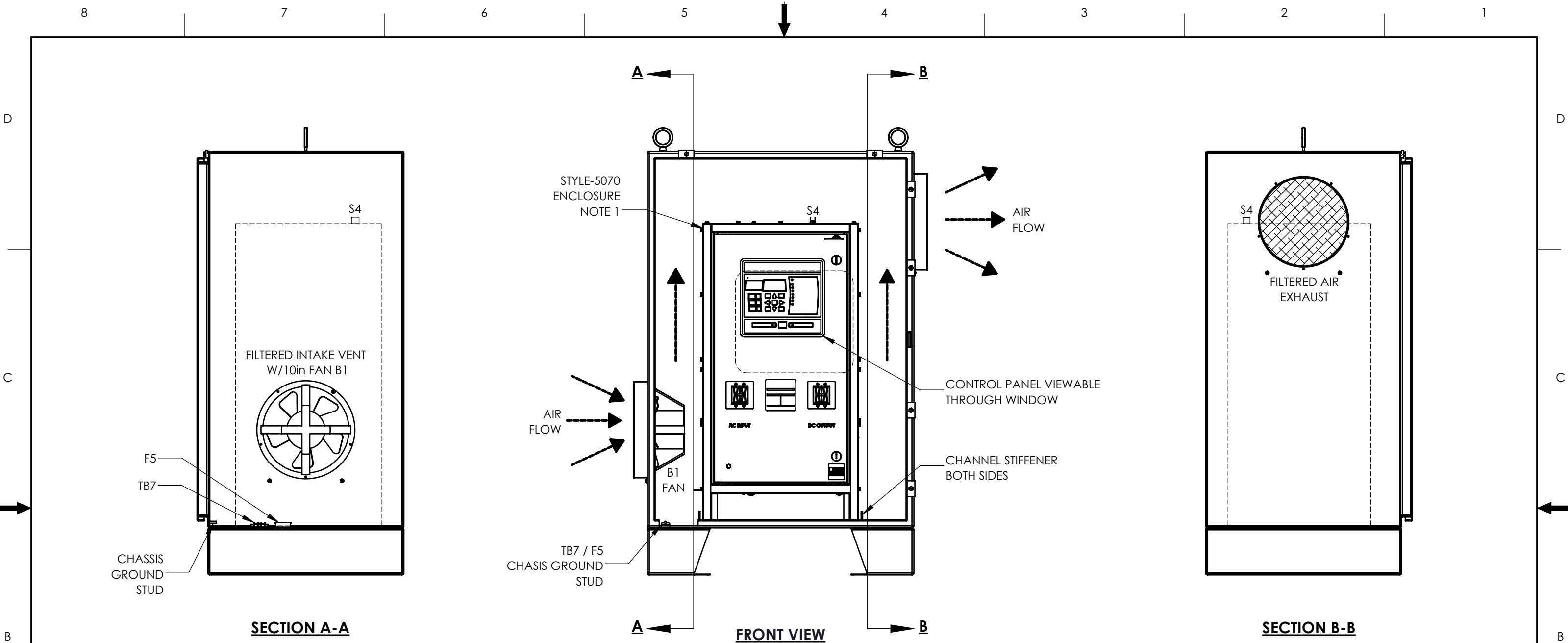

SECTION A-A

FRONT VIEW

SECTION B-B

NOTES:

- THIS DRAWING DEPICTS A NEMA TYPE 4 / IP66 CABINET, HOUSING A STANDARD NEMA-1 ATevo SERIES BATTERY CHARGER. SEE JE5309-00 (1PH) OR JE5331-00 (3PH) FOR INTERNAL STYLE-5070 ENCLOSURE DIMENSIONS.
- TB7 3-POS FAN EXTERNAL POWER TERMINAL BLOCK BARRIER TYPE, 6-32 BINDER HEAD SCREW TERMINAL, WILL ACCOMMODATE LUGS FOR #22-14 AWG WIRE.
- VENTING FAN (B1) IS INTERMITTENT, ACTIVATED BY THERMAL SWITCH (S4), WHICH CLOSES ON RISE AT 85 °F / 29.4 °C, AND IS SELF-RESETTING.

WIRE LIST				
No.	FROM	TO	GA	COLOR
196	TB7-L1	F5-1	14	BLACK
197	F5-2	S4-1	14	BLACK
198	S4-2	B1-1	14	BLACK
199	B1-2	TB7-N	14	BLACK
200	TB7-GND	CHASSIS GROUND	12	GRN/YEL

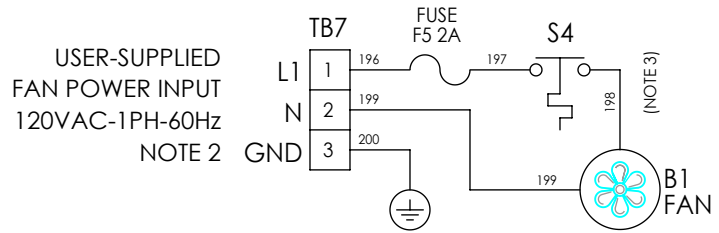

REV. 0	DRN BY	CHK BY	APP BY	DATE	DRN BY	DATE	TITLE ATEVO SERIES BATTERY CHARGER CABINET INTERNAL LAYOUT: NEMA TYPE 4 (12/13) STYLE-5037 ENCLOSURE
				1/6/2023	<i>KJB</i>	1/4/2023	
DESCRIPTION Initial Release					CHK BY <i>MCR</i>	DATE: 1/6/2023	
PROPRIETARY AND CONFIDENTIAL NOTICE ANY REPRODUCTION, PARTIAL OR AS A WHOLE OF THIS DOCUMENT WITHOUT THE WRITTEN PERMISSION OF HINDLE POWER, INC IS STRICTLY PROHIBITED.					APP BY <i>MS</i>	DATE: 1/11/2023	SCALE B 1:12
					UNLESS OTHERWISE SPECIFIED ALL DIMENSIONS FOLLOW THE ANSI SYSTEM IPS (INCHES-POUNDS & SECONDS) TOLERANCES ARE: FRAC. ±1/64, DEC. ±0.015, ANG ±.25°		
					DWG No JE5074-50		REV 0
							SHEET 2 OF 2