

- NOTE:**
1. USER TO CONNECT EXTERNAL POWER (120 Vac 1PH 60Hz) TO TERMINAL BLOCK (TB12), WHICH FEATURES 6-32 BINDER HEAD COMPRESSION SCREWS, ACCEPTING LUGS FOR #16-14 AWG WIRE.
 2. THERMAL SWITCH (S1) OPENS ON RISE TO 80 °F / 26.7 °C, SHUTTING DOWN HEATER, AND IS SELF-RESETTING. MOUNT CENTERED IN HEATSINK, AND 1/2IN FROM TOP EDGE (EXCEPT ON FM5001-10 SEE DIMENSION).
 3. COMPONENTS ARE CONNECTED WITH FLAME-RETARDANT SWITCHBOARD INSULATION TYPE WIRING, IDENTIFIED ON EACH END WITH NUMBER-CODED MARKERS. GROUND WIRE# 215 IS GREEN WITH YELLOW STRIPE. ALL WIRE RATED 105°C AND 600V. INSULATION SATISFIES NEMA WC-5 COLD BEND TO -40°C AND UL-62 (VW-1) VERTICAL FLAME RESISTANCE.

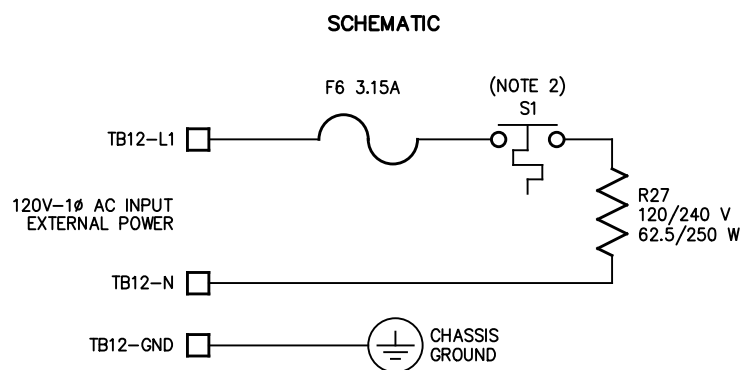
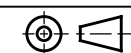

REV. 0	DRN BY KJB	CHK BY MCR	APP BY MCR	DATE 4/19/2022	DRN BY KJB	DATE: 4/19/2022	TITLE ATEVO BATTERY CHARGER STYLE-5054 CABINET HEATER
DESCRIPTION STANDARD DRAWINGS.					CHK BY MCR	DATE: 4/19/2022	
ECN NO. N/A					APP BY MCR	DATE: 4/19/2022	
						SCALE B NTS	DWG No EJ5165-01
						REV 0A	SHEET 1 OF 1