

INSTRUCTIONS:

1. TURN OFF (OPEN) AC INPUT CIRCUIT BREAKER (CB1), AND DC OUTPUT CIRCUIT BREAKER (CB2).
2. ALLOW INTERNAL VOLTAGES TO DISSIPATE.
3. OPEN DOOR PANEL, AND CAREFULLY REMOVE PLEXIGLASS SHIELDS.
4. USING A VOLTMETER, VERIFY ALL POTENTIAL VOLTAGES ARE AT "0".
5. LOCATE FILTER CAPACITOR ASSEMBLY (C1x/R9) ON REAR LEFT OF MOUNTING BASE.
6. REMOVE WIRE #20 AND #21 FROM LOWER CAPACITOR TERMINALS.
7. REMOVE #8 SELF TAPPING HARDWARE FASTENING ASSEMBLY TO CHASSIS.
8. PLACE SPARE CAP ASSEMBLY ON CHASSIS CENTERING SLOTS AROUND MOUNTING HOLES.
9. REPLACE #8 SELF TAPPING HARDWARE.
10. CONFIRM POARITY (+/-) OF CAPS BEFORE PROCEEDING.
11. REPLACE WIRE #20 AND WIRE #21 AS SHOWN BELOW.
12. IF SPARE IS FOR EJ5311-01, CONNECT WIRES AS INSTRUCTED. ENSURE (R9) RESISTOR IS STILL ATTACHED TO TERMINALS AS DEPICTED BELOW.

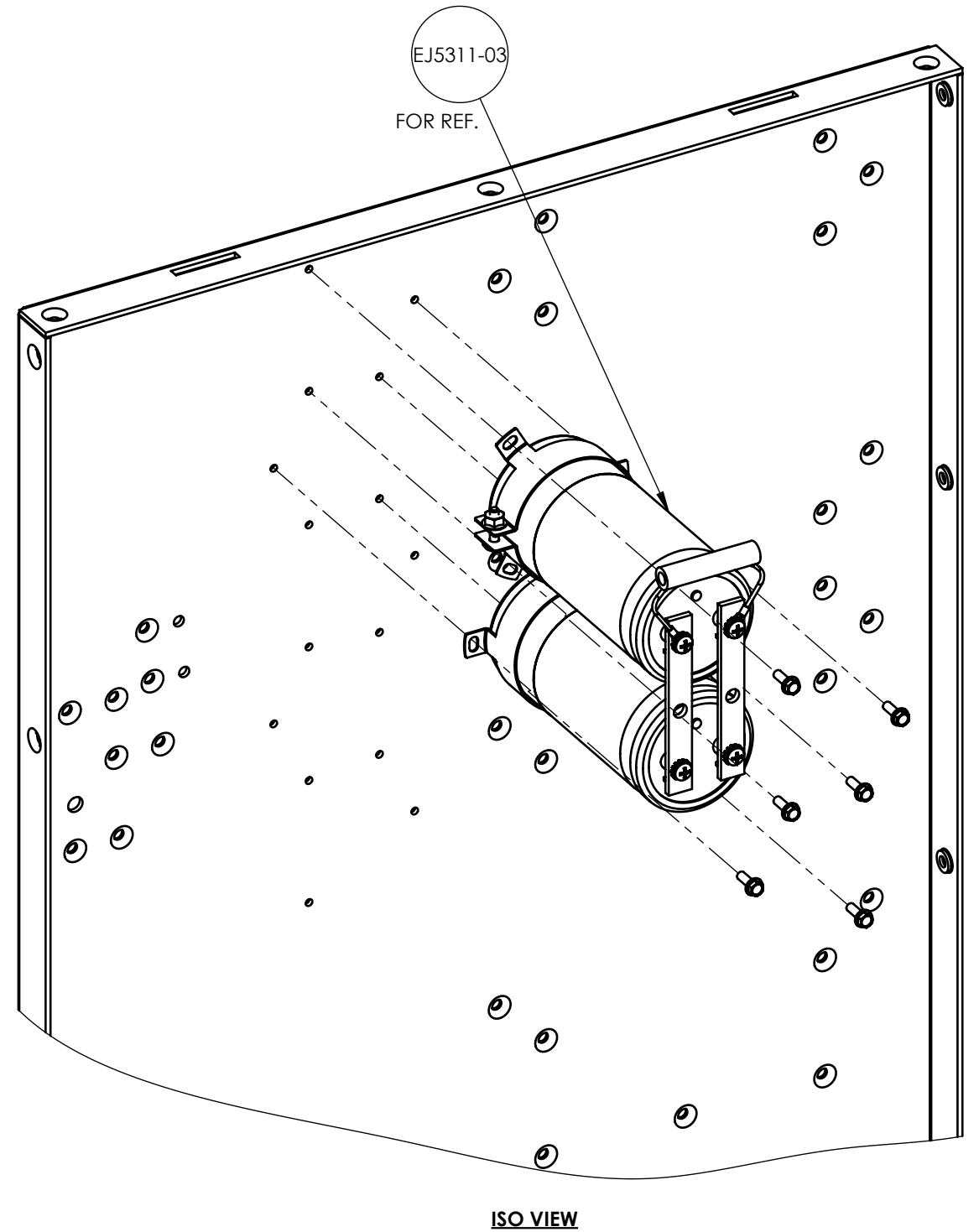
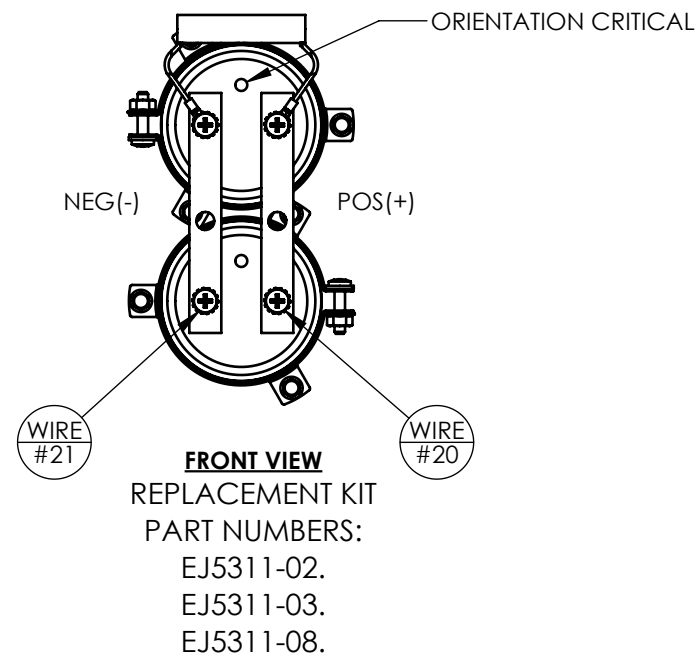
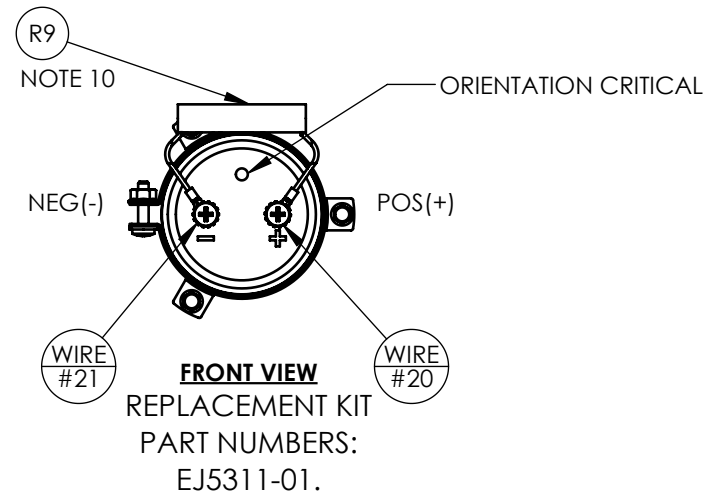

REV. 0	DRN BY	CHK BY	APP BY	DATE 3/28/2022	DRN BY <i>KJB</i>	DATE: 3/24/2022	HINDLEPOWER
DESCRIPTION Initial Release				CHK BY <i>MS</i>	DATE: 3/28/2022	TITLE ATevo Service Instructions C1/R9 Filter Capacitor Installation 75-100Adc Style-5070	
PROPRIETARY AND CONFIDENTIAL NOTICE ANY REPRODUCTION, PARTIAL OR AS A WHOLE OF THIS DOCUMENT WITHOUT THE WRITTEN PERMISSION OF HINDLE POWER, INC IS STRICTLY PROHIBITED.				APP BY <i>MCR</i>	DATE: 5/9/2022		
				UNLESS OTHERWISE SPECIFIED ALL DIMENSIONS FOLLOW THE ANSI SYSTEM IPS (INCHES-POUNDS & SECONDS) TOLERANCES ARE: FRAC. ±1/64, DEC. ±0.15, ANG ±.25°		DWG No JD5078-01	REV 0 SHEET 1 OF 1