

SEE DRAWING
JE5253-01

NOTE 3

NOTE 5

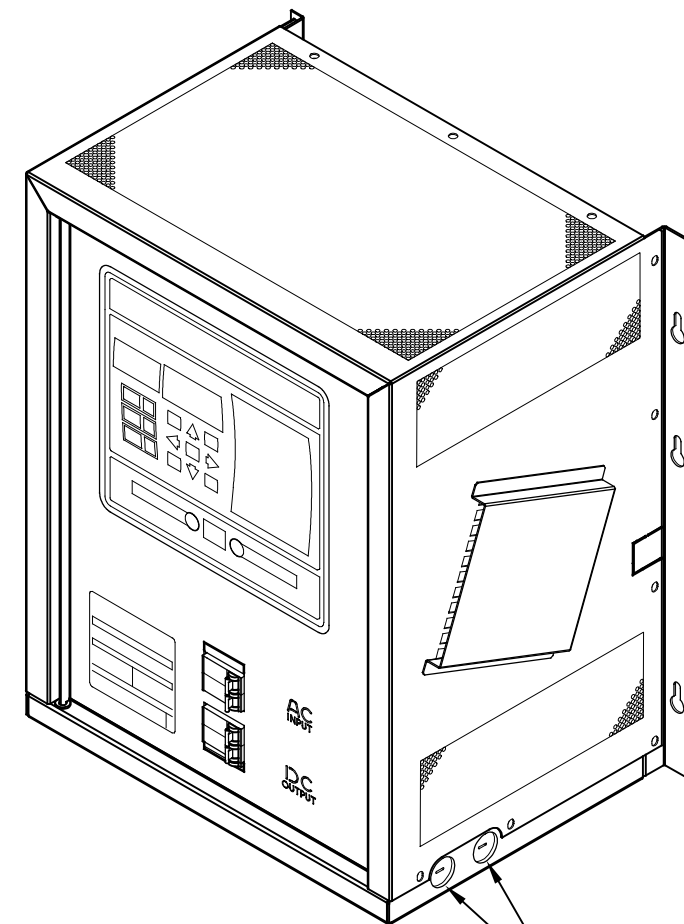
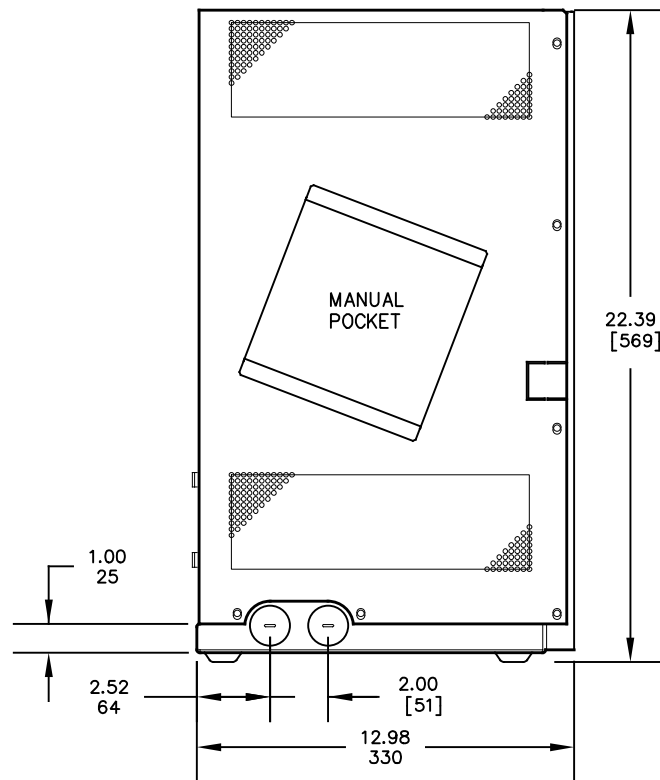
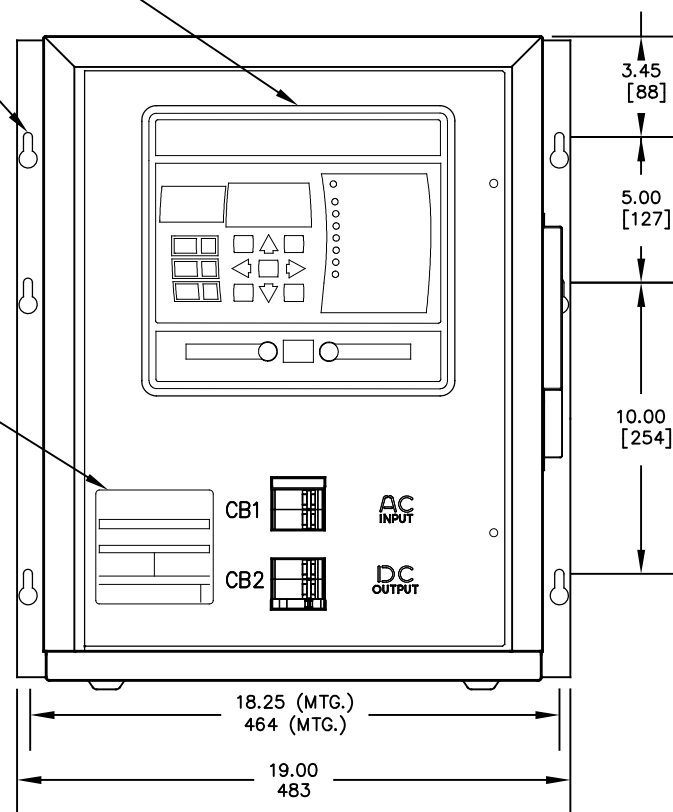

NOTE 4

NOTE 4

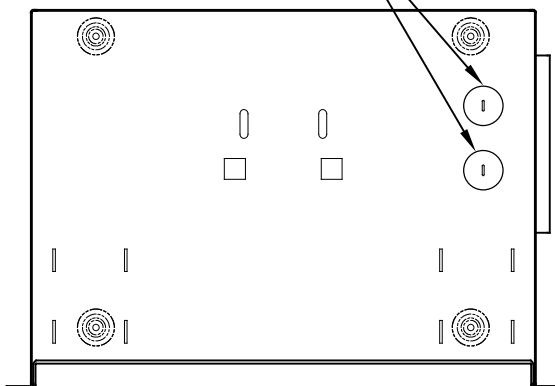

NOTES:

- ENCLOSURE IS A NEMA TYPE 1 / IP20 TOP-VENTED STEEL CABINET WITHOUT GASKETS. FINISH IS ANSI-61 GRAY EPOXY POWDERCOAT. BASE IS 14 GA. SHROUD IS 18 GA. DOOR IS 16 GA.
- ALLOW 6in / 152mm OF FREE AIR ON ALL VENTED SURFACES (TOP, SIDES & REAR) FOR COOLING.
- SIX (6) KEY-HOLE SLOTS ARE PROVIDED ON BACK OF ENCLOSURE AS SHOWN. FOR WALL-MOUNTING WITH 0.25in / 6.25mm HARDWARE.
- SIX (6) 1.31in / 33mm DIA KNOCKOUTS ARE PROVIDED AS SHOWN, WITH TWO (2) ADDITIONAL KNOCKOUTS FEATURED ON BOTTOM PANEL OF ENCLOSURE. USE OF ANY OF THESE FOUR (4) LOWER CONDUIT KNOCKOUTS WILL ALLOW REMOVAL OF CABINET SHROUD WITHOUT REMOVAL OF EXTERNAL WIRING.
- DATA NAMEPLATE DECAL (WITH CHARGER RATINGS) APPLIED TO DOOR.
- BATTERY CHARGER SHIPPING WEIGHT: SEE PRODUCT LITERATURE.

REV. A	DRN BY KJB	CHK BY MCR	APP BY MCR	DATE 2/22/2022	DRN BY KJB	DATE: 1/21/2021	<p>1075 Saint John Street Easton, PA 18042-6661 PH 610-330-9000 FAX 610-330-8510 www.hindlepowerinc.com</p>
DESCRIPTION STANDARD DRAWINGS.					CHK BY MCR	DATE: 1/21/2021	
ECN NO. N/A					APP BY MCR	DATE: 1/21/2021	
PROPERTY AND CONFIDENTIAL NOTICE ANY REPRODUCTION, PARTIAL OR AS A WHOLE OF THIS DOCUMENT WITHOUT THE WRITTEN PERMISSION OF HINDLE POWER, INC IS STRICTLY PROHIBITED.							TITLE ATEVO BATTERY CHARGER OUTLINE: NEMA-1 STYLE-5054 ENCL 1Ø W/O OPTIONS 130VAC 30-50A
DUAL DIMENSIONS in [mm]						B SCALE DWG No NTS JE5251-06	REV A SHEET 1 OF 1

SYM	STANDARD COMPONENT DESCRIPTION
A1	MAIN CONTROL PC BOARD
A2	POWER BOARD
A6	RECTIFIER H/S ASSEMBLY
A7	FILTER BOARD (C1x/R9x)
A9	MOV BOARD
CB1	AC INPUT CIRCUIT BREAKER C60-K 2P
CB2	DC OUTPUT CIRCUIT BREAKER C60-K 2P
AUXCB2	DC CKT BKR (CB2) AUXILIARY CONTACTS
L1	MAIN INDUCTOR
L2	FILTER INDUCTOR
T1	POWER ISOLATION TRANSFORMER

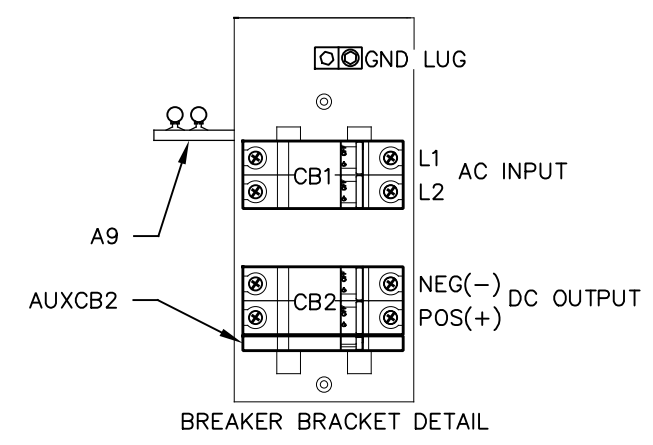
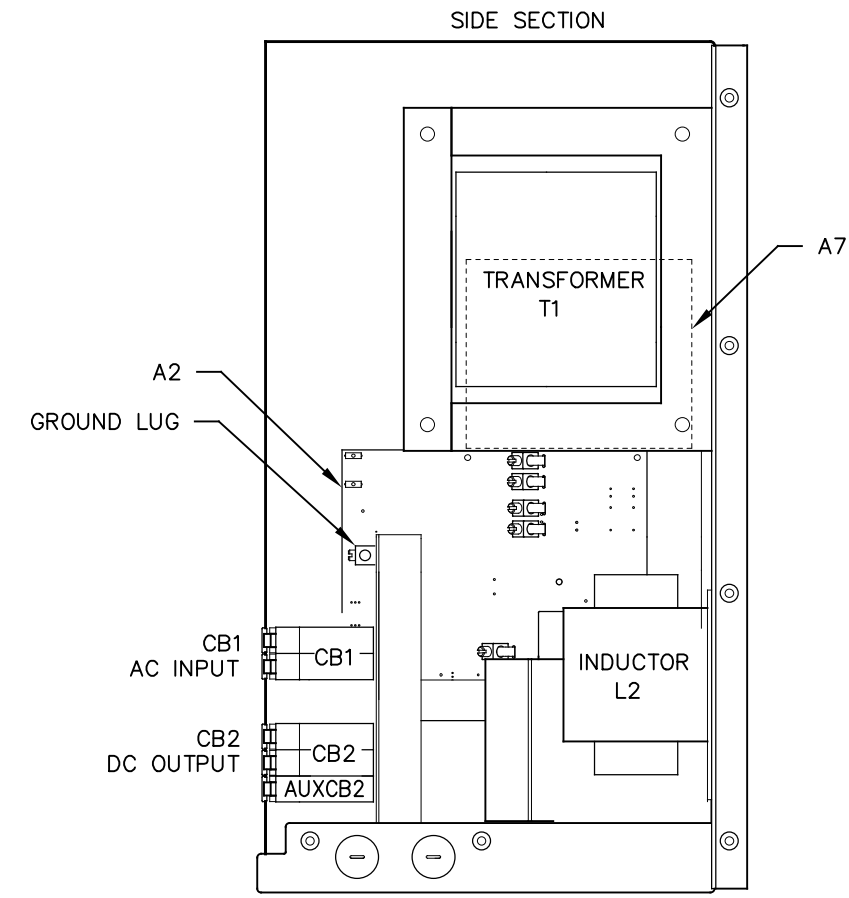
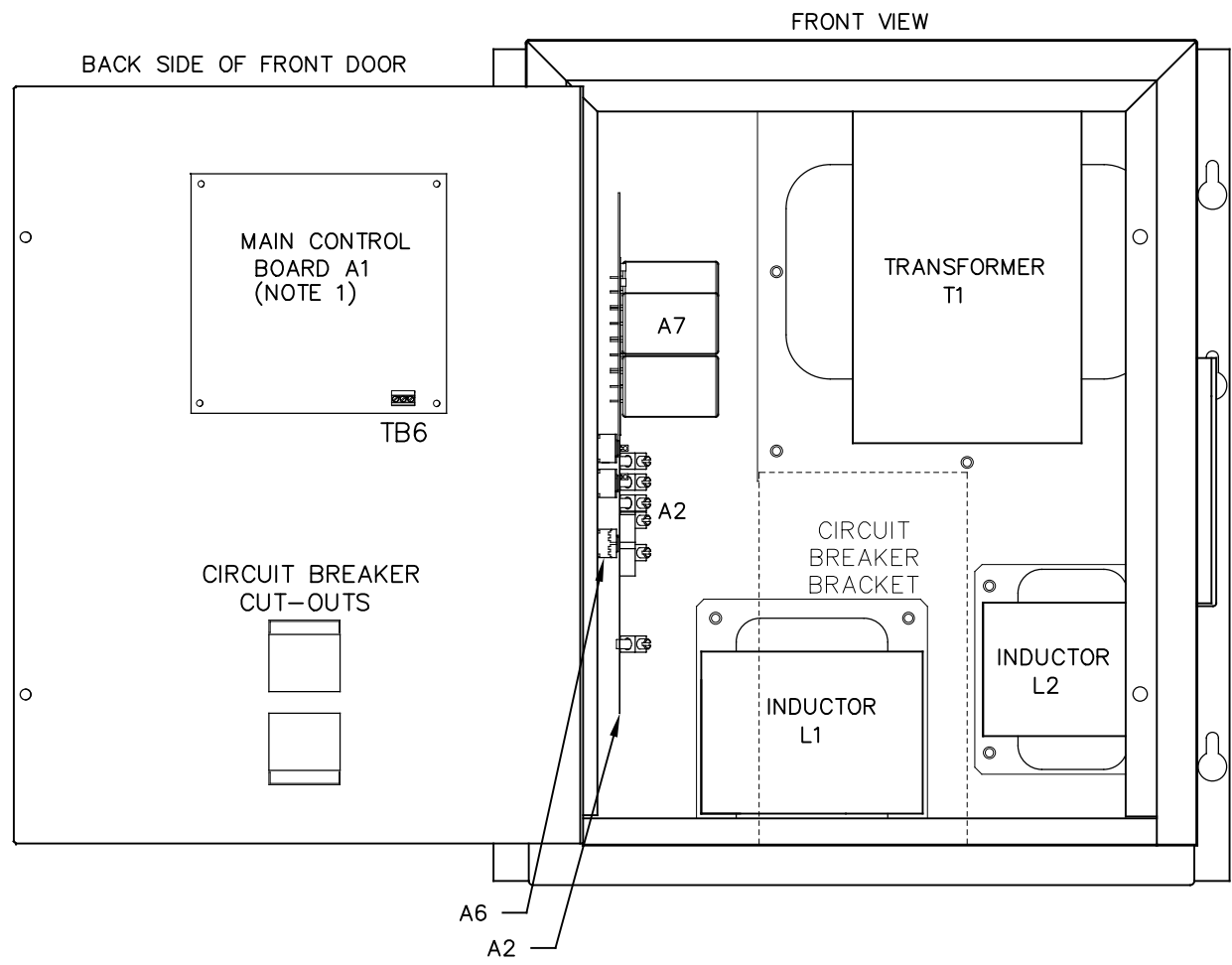

NOTES:
 1. FOR DETAIL VIEWS OF ALL PC BOARDS (A1, A2, A4 etc.) SEE DRAWING JE5253-06.

I/O TERMINAL	DESCRIPTION - TYPE	CONNECTION
CB2 (+/-)	POS/NEG DC OUTPUT TERMINALS - CKT BREAKER COMPRESSION LUG	#18-4 AWG
GND LUG	USER GROUND TERMINAL - CU-ALUMINUM COMPRESSION LUG	#14-6 AWG
CB1 (L1/L2)	AC INPUT TERMINALS - CKT BREAKER COMPRESSION LUG	#18-4 AWG
(A2) TB1	POS/NEG REMOTE SENSE TERMS (A2) - SOLDERLESS COMP SCREW	#22-14 AWG
(A2) TB8	TEMPCO PROBE (A10) TERM BLK - SOLDERLESS COMP SCREW	#22-14 AWG
(A1) TB6	SUMMARY ALARM TERMINAL BLOCK (A1) - SOLDERLESS COMP SCREW	#22-14 AWG

REV. DRN BY A KJB	CHK BY MCR	APP BY MCR	DATE 2/22/2022	DRN BY KJB	DATE 1/21/2021		1075 Saint John Street Easton, PA 18042-6661 PH 610-330-9000 FAX 610-330-8510 www.hindlepowerinc.com	
DESCRIPTION STANDARD DRAWINGS.				CHK BY MCR	DATE 1/21/2021		ATEVO BATTERY CHARGER INTERNAL COMPONENT LAYOUT: STYLE-5054 1Ø W/O OPTIONS 130VAC 30-50A	
ECN NO. N/A				APP BY MCR	DATE 1/21/2021	B SCALE DWG No NTS JE5252-06		REV A
PROPERTY AND CONFIDENTIAL NOTICE ANY REPRODUCTION, PARTIAL OR AS A WHOLE OF THIS DOCUMENT WITHOUT THE WRITTEN PERMISSION OF HINDLE POWER, INC IS STRICTLY PROHIBITED.								

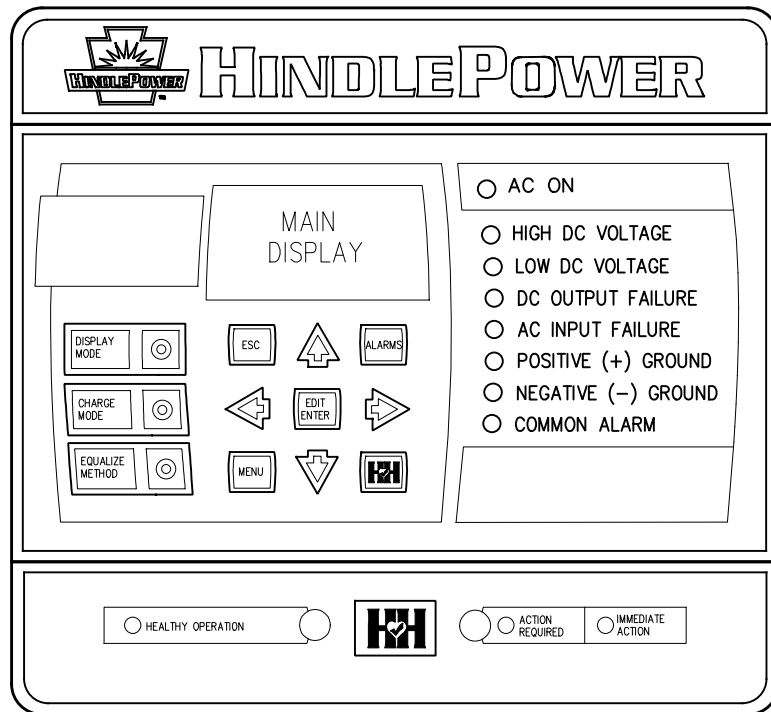

CONTROL PANEL
(PART No. FK5047-00)

NOTE: ALL ALARM CONTACTS ARE ENERGIZED WHEN IN THE NON-ALARM STATE (FAIL SAFE). ALL ALARM CONTACTS WILL CHANGE STATE WHEN CHARGER IS POWERED DOWN. CONTACT RATING IS 0.5A @ 125VAC/VDC RESISTIVE.

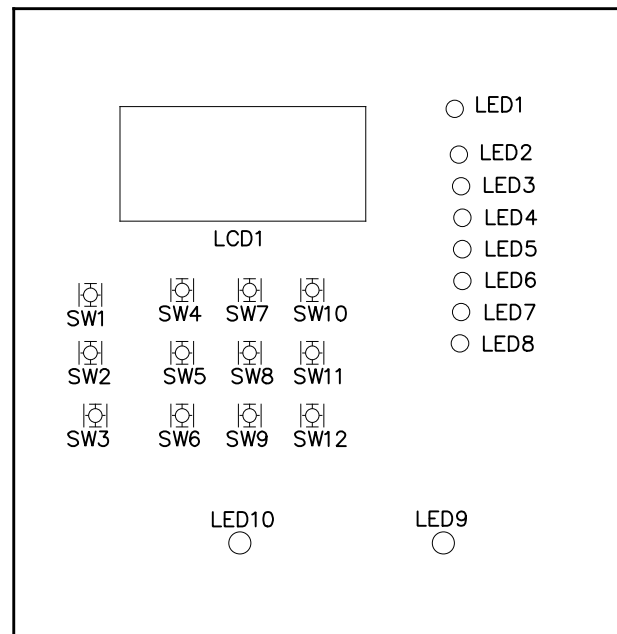

MAIN CONTROL PC BOARD (A1)
FRONT VIEW – FACING CHARGER DOOR WHEN INSTALLED

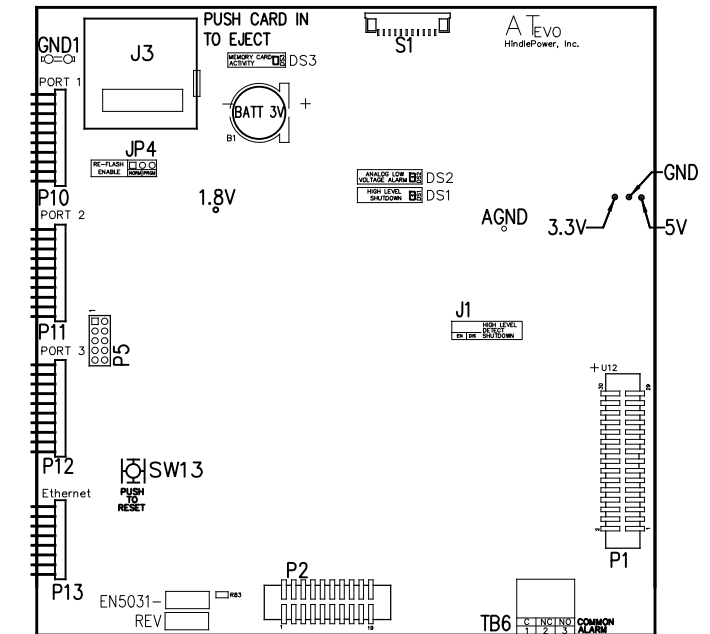

MAIN CONTROL PC BOARD (A1)
BACK VIEW – FACING CHARGER COMPONENTS WHEN INSTALLED

MAIN CONTROL PC BOARD (A1)

INDICATOR LIGHTS (LEDs):

- LED1 – GREEN – AC ON
- LED2 – RED – HIGH DC VOLTAGE ALARM
- LED3 – RED – LOW DC VOLTAGE ALARM
- LED4 – RED – DC OUTPUT FAILURE ALARM
- LED5 – RED – AC INPUT FAILURE ALARM
- LED6 – RED – POSITIVE (+) GROUND ALARM
- LED7 – RED – NEGATIVE (-) GROUND ALARM
- LED8 – RED – COMMON ALARM
- LED9 – RED – ACTION REQUIRED ALARM
- LED10 – GREEN – HEALTHY OPERATION
- DS1 – RED – HIGH LEVEL SHUTDOWN (HLD)
- DS2 – RED – ANALOG LOW VOLTAGE ALARM (LLD)
- DS3 – RED – MEMORY CARD ACTIVITY

JUMPERS:

- J1 – ANALOG HIGH VOLTAGE SHUTDOWN JUMPER
- J3 – SD CARD PORT
- JP4 – RE-FLASH (FIELD PROGRAMMING) JUMPER
- TERMINAL BLOCKS:
- TB6 – COMMON ALARM RELAY CONTACTS
- TEST POINTS:
- 1.8V – 1.8 VOLTS
- 3.3V – 3.3 VOLTS
- 5V – 5.0 VOLTS
- GND – GROUND
- AGND – ANALOG GROUND
- SDA – MAIN BOARD 12C DATA
- SCL – MAIN BOARD 12C CLOCK

SWITCHES:

- S1 – DISPLAY BUTTON
- S2 – CHARGE MODE BUTTON
- S3 – EQUALIZE METHOD BUTTON
- S4 – ESCAPE (ESC) BUTTON
- S5 – LEFT ARROW BUTTON
- S6 – MENU BUTTON
- S7 – UP ARROW BUTTON
- S8 – EDIT / ENTER BUTTON
- S9 – DOWN ARROW BUTTON
- S10 – ALARM BUTTON
- S11 – RIGHT ARROW BUTTON
- S12 – HINDLE HEALTH (HHS) BUTTON
- SW13 – SYSTEM RESET BUTTON (BACK OF BOARD)

CONNECTORS:

- P1 – POWER BOARD RIBBON
- P2 – 3 PHASE RECTIFIER RIBBON
- P3 – USB EXPANSION PORT
- P4 – SPI & I2C EXPANSION PORT #1
- P5 – SPI & I2C EXPANSION PORT #2
- P6 – DISPLAY SPI PORT
- P7 – DISPLAY JTAG PORTS
- P10 – SERIAL INTERFACE PORT #1
- P11 – SERIAL INTERFACE PORT #2
- P12 – SERIAL INTERFACE PORT #3
- P13 – ETHERNET INTERFACE PORT
- P17 – GENERAL EXPANSION PORT

I/O TERMINAL	DESCRIPTION – TYPE	CONNECTION
(A1) TB6	SUMMARY ALARM TERMINAL BLOCK (A1) – SOLDERLESS COMP SCREW	#22-14 AWG

REV. A	DRN BY KJB	CHK BY MCR	APP BY MCR	DATE 2/22/2022	DRN BY KJB	DATE 1/21/2021
DESCRIPTION				CHK BY MCR	DATE 1/21/2021	
STANDARD DRAWINGS.				APP BY MCR	DATE 1/21/2021	
ECN NO. N/A				PROPERTY AND CONFIDENTIAL NOTICE		
ANY REPRODUCTION, PARTIAL OR AS A WHOLE OF THIS DOCUMENT WITHOUT THE WRITTEN PERMISSION OF HINDLE POWER, INC IS STRICTLY PROHIBITED.						

1075 Saint John Street
Easton, PA 18042-6661
PH 610-330-9000 FAX 610-330-8510
www.hindlepowerinc.com

HINDLEPOWER

TITLE
ATEVO BATTERY CHARGER
CONTROL PANEL / PC BOARD DETAIL
1Ø W/O OPTIONS 130VAC 30-50A

B	SCALE	DWG No	JE5253-06	REV	SHEET
	NTS			A	1 OF 2

FILTER BOARD (A7)

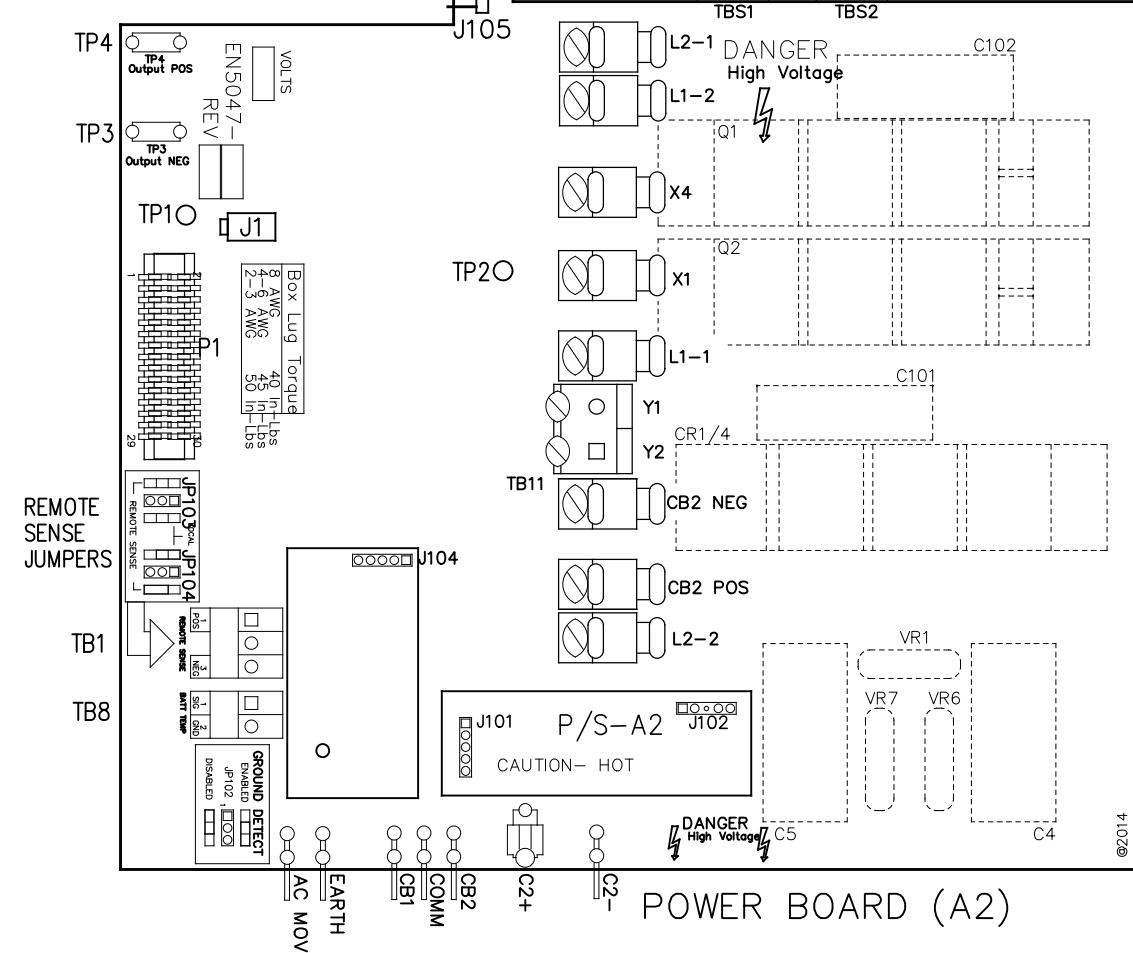
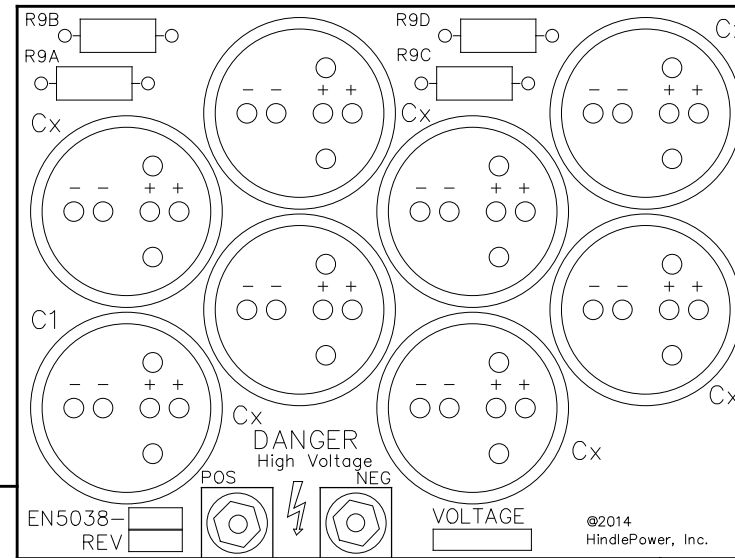

USER TERMINALS ON POWER BOARD (A2):

- TB1 - REMOTE VOLTAGE SENSE
- TB8 - BATTERY TEMPERATURE COMPENSATION

JUMPERS ON POWER BOARD (A2):

- JP102 - GROUND DETECT CIRCUIT ENABLE / DISABLE
- JP103 - REMOTE OR LOCAL SENSE SELECTOR (+)
- JP104 - REMOTE OR LOCAL SENSE SELECTOR (-)

CONNECTORS ON POWER BOARD (A2):

- J1 - POWER OUT
- J101 - DC POWER SUPPLY
- J102 - DC POWER SUPPLY
- J105 - AUXILIARY I/O BOARD
- P1 - MAIN CONTROL BOARD RIBBON

DISCRETE TERMINALS:

- AC MOV - CHASSIS EARTH GROUND
- EARTH - CHASSIS EARTH GROUND (DOOR)
- CB1 - AC BREAKER AUX SWITCH CONTACT
- CB2 - DC BREAKER AUX SWITCH CONTACT
- COMM - BREAKER AUX SWITCH COMMON
- C2+ - ELIMINATOR FILTER CAPACITOR (+)
- C2 - ELIMINATOR FILTER CAPACITOR (-)
- X1 - TRANSFORMER SECONDARY WINDING
- X4 - TRANSFORMER SECONDARY WINDING
- L1-1 - FILTER INDUCTOR #1 (TERMINAL #1)
- L1-2 - FILTER INDUCTOR #1 (TERMINAL #2)
- L2-1 - FILTER INDUCTOR #2 (TERMINAL #1)
- L2-2 - FILTER INDUCTOR #2 (TERMINAL #2)
- TB10 - CB2 DC BREAKER
- TB11 - 'Y' CONTROL WINDINGS
- TBS1 - FILTER CAPACITOR BOARD (+)
- TBS2 - FILTER CAPACITOR BOARD (-)

TEST POINTS ON POWER BOARD (A2):

- TP1 - PRE-FILTERED DC BUS (-)
- TP2 - PRE-FILTERED DC BUS (+)
- TP3 - DC BUS (-)
- TP4 - DC BUS (+)

I/O TERMINAL	DESCRIPTION - TYPE	CONNECTION
(A2) TB1	POS/NEG REMOTE SENSE TERMS (A2) - SOLDERLESS COMP SCREW	#22-14 AWG
(A2) TB8	TEMPCO PROBE (A10) TERM BLK - SOLDERLESS COMP SCREW	#22-14 AWG



1075 Saint John Street
 Easton, PA 18042-6661
 PH 610-330-9000 FAX 610-330-8510
 www.hindlepowerinc.com

TITLE
ATEVO BATTERY CHARGER
CONTROL PANEL / PC BOARD DETAIL
1Ø W/O OPTIONS 130VAC 30-50A

B	SCALE	DWG No	REV	SHEET
	NTS	JE5253-06	A	2 OF 2

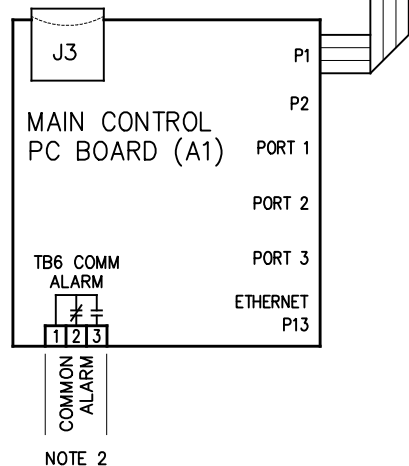
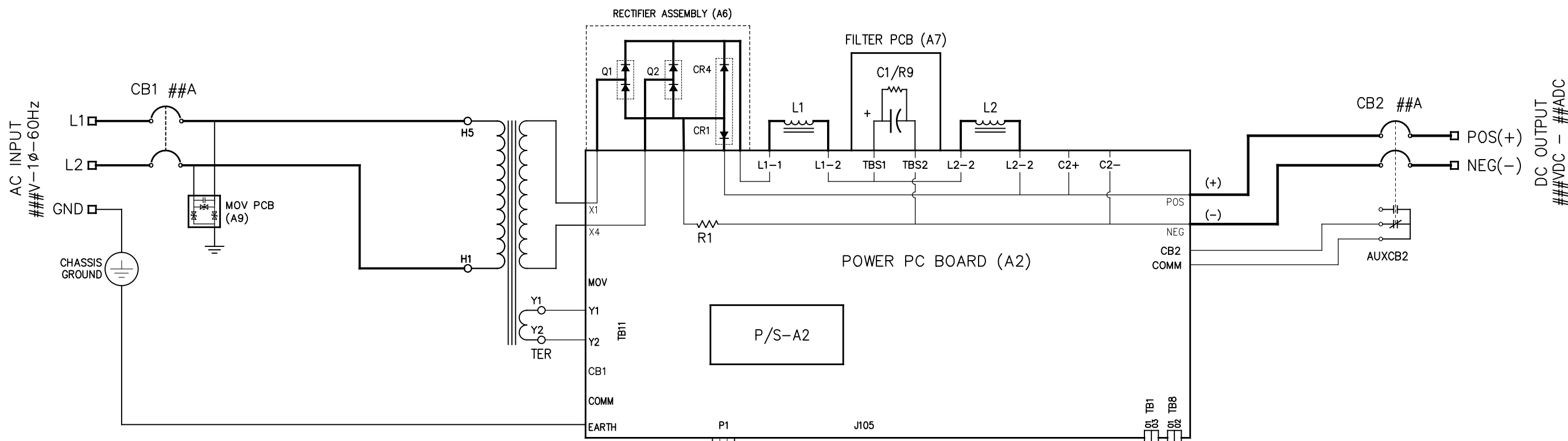

NOTE 2

NOTES:

1. FOR PHYSICAL COMPONENT FEATURES OF PC BOARDS (A1, A2, A4, A7 etc.) SEE DETAIL DRAWING JE5253-06.
2. ALL ALARM CONTACTS SHOWN IN NON-ALARM STATE, WITH CHARGER ENERGIZED AND ALARM RELAYS ENERGIZED (FAIL SAFE). ALL ALARM CONTACTS WILL CHANGE STATE WHEN CHARGER IS POWERED DOWN. CONTACT RATING IS: 0.5A @ 125VAC/VDC RESISTIVE.

REV. A	DRN BY KJB	CHK BY MCR	APP BY MCR	DATE 2/22/2022	DRN BY KJB	DATE 1/21/2021	<p>1075 Saint John Street Easton, PA 18042-6661 PH 610-330-9000 FAX 610-330-8510 www.hindlepowerinc.com</p>
DESCRIPTION				STANDARD DRAWINGS.	CHK BY MCR	DATE 1/21/2021	
ECN NO. N/A				APP BY MCR	DATE 1/21/2021	TITLE	
PROPERTY AND CONFIDENTIAL NOTICE				ANY REPRODUCTION, PARTIAL OR AS A WHOLE OF THIS DOCUMENT WITHOUT THE WRITTEN PERMISSION OF HINDLE POWER, INC IS STRICTLY PROHIBITED.		<p>B SCALE DWG No</p> <p>NTS JE5254-06</p>	
						REV A	SHEET 1 OF 1

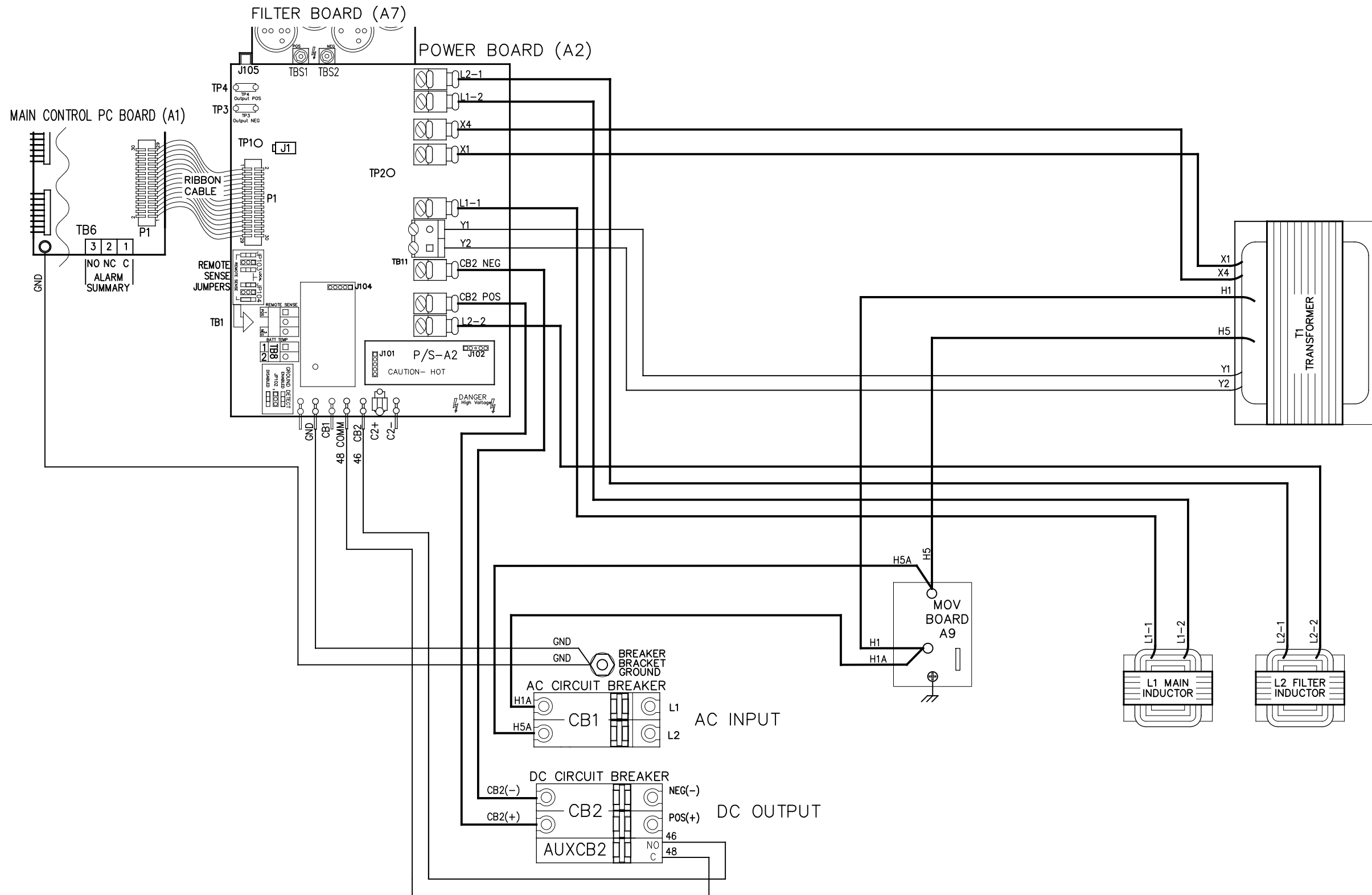

NOTES:

1. WHEN NATURAL LEADS OF MAGNETICS ARE NOT USED, CHARGER COMPONENTS ARE CONNECTED WITH BLACK FLAME-RETARDANT SWITCHBOARD INSULATION SYSTEM (SIS) TYPE WIRING, IDENTIFIED ON EACH END WITH NUMBER-CODED MARKERS. GROUND WIRES ARE GREEN WITH YELLOW STRIPE.

REV. A	DRN BY KJB	CHK BY MCR	APP BY MCR	DATE 2/22/2022	DRN BY KJB	DATE 1/21/2021	<p>1075 Saint John Street Easton, PA 18042-6661 PH 610-330-9000 FAX 610-330-8510 www.hindlepowerinc.com</p>		
DESCRIPTION STANDARD DRAWINGS.					CHK BY MCR	DATE 1/21/2021			
ECN NO. N/A					APP BY MCR	DATE 1/21/2021			
PROPERTY AND CONFIDENTIAL NOTICE ANY REPRODUCTION, PARTIAL OR AS A WHOLE OF THIS DOCUMENT WITHOUT THE WRITTEN PERMISSION OF HINDLE POWER, INC IS STRICTLY PROHIBITED.							TITLE ATEVO BATTERY CHARGER CONN DIAGRAM: STYLE 5070 1Ø W/O OPTIONS 130VAC 30-50A		
					B	SCALE NTS	DWG No JE5255-06	REV A	SHEET 1 OF 1